



INSTALLATION INSTRUCTIONS



INDEX

LET-LOK TUBE FITTINGS

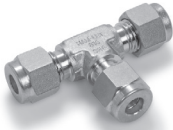

3

ONE-LOK TUBE FITTINGS



4

PIPELINE PRECISION INSTRUMENTATION PIPE FITTING



5

HTC HI-TECH COMPONENTS



5

TBV SERIES TRUNNION BALL VALVES



6

H-6800 SERIES INSTRUMENTATION BALL VALVES



7

HEAVY DUTY BALL VALVES H-1700 SERIES



8

H-500 SERIES 3-PIECE BALL VALVES



9

H-700 SERIES BALL VALVES WITH LOCKING DEVICE



10

SCREWED BONNET NEEDLE VALVES H-99



11

H300U SERIES. NEEDLE VALVES



12

H-400 SERIES CHECK VALVES



13

H-900 SERIES RELIEF VALVES



14

H900-HP SERIES HIGH PRESSURE RELIEF VALVES



18

H600 SERIES T-TYPE & IN-LINE FILTERS



22

PRESSURE GAUGES INSTALLATION & OPERATION INSTRUCTIONS



23

LET-LOK[®] TUBE FITTINGS

1/16" through 1" - Inch, 2 mm through 25 mm - Metric

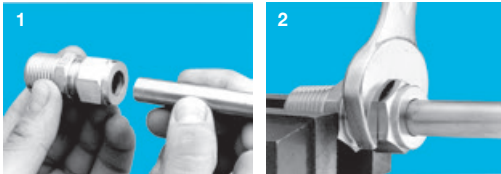

LET-LOK[®] fittings are supplied assembled and finger tight. Disassembly before use may allow the entry of dirt or other particles.

1. Insert the tubing into the LET-LOK fitting. Check that the tube rests firmly on the fitting shoulder and that the nut is finger tight.
2. Tighten the nut. 1 1/4 turns of the nut are required for 1/4" (6 mm) and higher. (See Figure A.) 3/4 of a turn of the nut required for 3/16" (4 mm) and lower (See Figure B.)

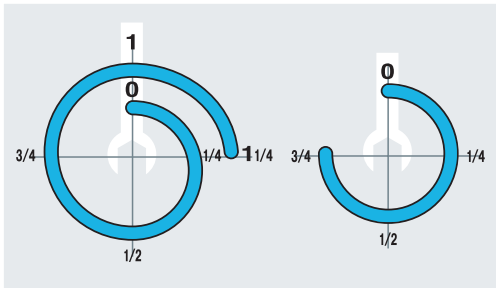

REASSEMBLY INSTRUCTIONS

LET-LOK connections may be disconnected and remade repeatedly without loss of the leak-tight seal.

1. Before disconnecting, mark the position of the nut in relation to the fitting body.
2. To reassemble, use a wrench to tighten the nut to original position.
3. Tighten slightly with a wrench until you feel a slight rise in torque.

TUBE CUTTING

There are two ways to cut tubes:

1. Tube cutter
2. Hacksaw

TUBE CUTTER

To attain a leak-free connection, cut the tubing squarely. Use a good quality tube cutter with the appropriate blade for the tubing.

Do not try to reduce the time of cutting by taking deep cuts with each turn of the cutter. This will work-harden the tube. Deburr the end of the tube to avoid damage to the fitting and to ensure that the tube reaches the bottom of the fitting.

HACKSAW CUTTING

In order to cut the tube with a hacksaw and achieve square ends, cut the tube with guide blocks.

If you use this method of cutting, you will need to deburr the tube ends.

Warning!

Do not hold the tube in a vise at the place where it will be inserted into the fitting (the vise will leave a mark on the tube that may cause leaks and might cause ovality).

TUBE HANDLING

Scratches on the tube might cause leaks. Therefore, use caution in handling the tube in order to reduce the possibility of leaks.

Precautions:

1. Do not drag tubes on the floor.
2. Do not drag tubes out of the tube rack, especially in case of large OD tubes.

COPPER TUBING

If you use copper tubing on a row, be sure to hold the end of the tube, then move the tubing away from you, so that it can lie on a flat surface.

ONE-LOK® TUBE FITTINGS

1/4", 3/8", 1/2", 3/4", 1"

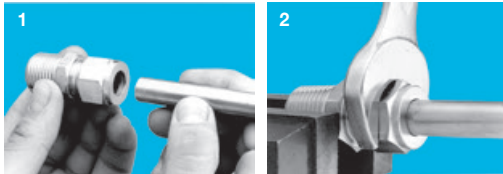

ONE-LOK fittings are supplied assembled and finger tight. Disassembly before use may allow the entry of dirt or other particles.

1. Insert the tubing into the ONE-LOK® fitting. Check that the tube rests firmly on the fitting shoulder and that the nut is finger tight.
2. Tighten the nut. 1 1/4 turns of the nut are required. (See Figure A.)

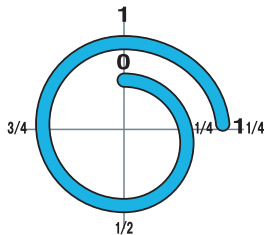

REASSEMBLY INSTRUCTIONS

ONE-LOK connections may be disconnected and remade repeatedly without loss of the leak-tight seal.

1. Before disconnecting, mark the position of the nut in relation to the fitting body.
2. To reassemble, use a wrench to tighten the nut to original position.
3. Tighten slightly with a wrench until you feel a slight rise in torque.

TUBE CUTTING

There are two ways to cut tubes:

1. Tube cutter
2. Hacksaw

TUBE CUTTER

To attain a leak-free connection, cut the tubing squarely. Use a good quality tube cutter with the appropriate blade for the tubing.

Do not try to reduce the time of cutting by taking deep cuts with each turn of the cutter. This will work-harden the tube. Deburr the end of the tube to avoid damage to the fitting and to ensure that the tube reaches the bottom of the fitting.

HACKSAW CUTTING

In order to cut the tube with a hacksaw and get square ends, cut the tube with guide blocks.

If you use this method of cutting, you will need to deburr the tube ends.

Warning!

Do not hold the tube in a vise at the place where it will be inserted into the fitting (the vise will leave a mark on the tube that may cause leaks and might cause ovality).

TUBE HANDLING

Scratches on the tube might cause leaks. Therefore, use caution in handling the tube in order to reduce the possibility of leaks.

Precautions:

1. Do not drag tubes on the floor.
2. Do not drag tubes out of the tubing rack, especially in case of large OD tubes.

COPPER TUBING

If you use copper tubing on a row, be sure to hold the end of the tube, then move the tubing away from you, so that it can lie on a flat surface.

UCT PRECISION INSTRUMENTATION PIPE FITTINGS PIPELINE

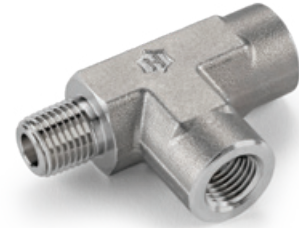

To ensure a leak-tight seal, UCT Fluid Solutions recommends that you use a pipe-thread sealant on all NPT threads. The most effective sealing method is PTFE tape.

Tape should be used only on male tapered pipe threads. Do not use tape on flared, coned or tube fitting ends! Clean both male and female tapered threads. Wrap tape in the direction of the male tapered thread spiral.

Note: We suggest two wraps for stainless-steel tapered pipe threads. Make sure the tape does not overhang the first thread. Otherwise, the tape could shred and enter the fluid system. Cut off excess tape. The connection is now ready for proper makeup.

HI-TECH COMPONENTS - HTC

MAKE UP OF GLANDS

- Glands offer a high-purity metal-to-metal seal for leak-free service in high-vacuum or high-pressure assemblies.
- The gasket is compressed by two highly polished beads when the male and female nuts are engaged.
- The gland bead-to-bead assembly compresses a soft metal gasket-to-seal. This assembly can be locked by the UCT Grip-Kit (see A below).
- Visual testing and leak testing are performed through two testing ports in opposite locations from the female nut.

ASSEMBLY INSTRUCTIONS

1. Be sure to protect all HTC face-seal fittings until the assembly and make up. Exercise great care to ensure that the sealing surfaces are not scratched, damaged or contaminated in any way during handling and assembly.

2. Always use a clean environment, and always employ proper clean-room protocol for make up and assembly of high-purity fittings and applications.
3. Make up instructions:
Tighten the female nut to the male nut/body until it is finger tight. Tighten the female nut 1/8 of a turn past the finger-tight point. Always torque the female nut while keeping the male nut/body stationary.
Face-seal connections are remarkable - please use a new gasket for each remake.

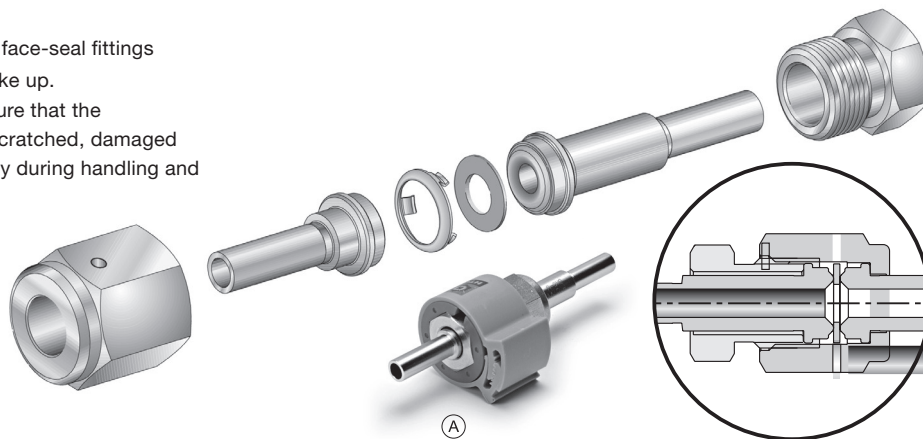

TRUNNION BALL VALVE

TBV SERIES



GENERAL NOTE

When a ball valve is removed or installed in a tube system, a back-up wrench (spanner) must be used on the end connector, NOT on the valve body.

Tube Fitting Connectors (LET-LOK Twin-Ferrule Compression Fittings)

1. Insert the tubing, nesting it in the counterbore.
2. Ensure that the nut is finger tight, and mark the nut for reference.
3. Now tighten the nut 1 1/4 turns.

Note: For sizes 1/16" to 3/16" (2mm to 4 mm), tighten 3/4 of a turn only from the finger tight position.

TAPER THREADED CONNECTORS

(NPT, BSPT, Male or Female)

1. On the male thread of the connector, apply PTFE tape or a high-quality sealing compound. When PTFE tape is used, no more than two full turns of the tape should be applied. The tape must not overhang the end of the connector.
2. Screw the valve and connector together until they are hand tight.
3. With the proper size wrench (spanner), holding both sides of the connector (not the valve body), continue to tighten until a leak-tight joint is achieved.

INSTALLATION OF PANEL-MOUNTING VALVES

MAX. Panel Thickness	Panel Hole Diameter
0.38" (9.7 mm)	0.88" (22.5mm)

1. Remove the handle by turning the set screw counter-clockwise using the appropriate hex-socket tool.
2. Insert the valve through the panel hole and assemble the panel nut. Note: If the valve is mounted on a thin panel, it may be necessary to fit a spacer (washer) to the valve to allow proper engagement of the panel nut.
3. If required, adjust the stem packing as explained above. Replace the handle and retighten the set screw.

MAXIMUM ALLOWABLE WORKING PRESSURES AND TEMPERATURES

Max. Pressure Rating At 70°F (21°C)

Pressure per LET-LOK Size

In	Pressure	mm	Pressure
1/4"	10000 psi	6	10000 psi
3/8"	6500 psi	8,10	6500 psi
1/2"	6500 psi	4	6500 psi

For allowable pressure at various temperatures, see the graph in the main catalogue.

WARNING!

The system designer and user have the sole responsibility for selecting products suitable for their special application requirements, ensuring their safe and trouble-free installation, operation, and maintenance. Application details, material compatibility and product ratings should all be considered for each selected product. Improper selection, installation or use of products can cause property damage or personal injury.

INSTRUMENTATION BALL VALVES

H-6800 SERIES



1. USE

For maximum valve life, use the valve only within the stated pressure and temperature range, and in accordance with the corrosion resistance of the material.

2. GENERAL NOTE

When a ball valve is removed or installed in a tube system, a back-up wrench (spanner) must be used on the end connector, NOT on the valve body.

Tube Fitting Connectors (LET-LOK Twin-Ferrule Compression Fittings)

1. Insert the tubing, nesting it in the counterbore.
2. Ensure that the nut is finger tight and mark the nut for reference.
3. Now tighten the nut 1 1/4 turns.

Note: For sizes 1/16" to 3/16" (2mm to 4 mm), tighten 3/4 of a turn only from the finger tight position.

3. TAPER THREADED CONNECTORS

(NPT, BSPT, Male or Female)

1. On the male thread of the connector, apply PTFE tape or a high-quality sealing compound. When PTFE tape is used, no more than two full turns of the tape should be applied. The tape must not overhang the end of the connector.
2. Screw the valve and connector together until they are hand tight.
3. With the proper size wrench (spanner), holding both sides of the connector (not the valve body), continue to tighten until a leak-tight joint is achieved.

4. WELDED CONNECTORS

1. We recommend disassembling all valves prior to welding in order to avoid damage to seats and seals.
2. If the valve must be welded when fully assembled, put the valve in the full open position, and continuously purge it with cool gas. People who have been trained in established procedures should perform all the welding tasks.
3. For socket weld ports: insert the tube into the connector until it bottoms out against the stop, then pull it back approximately 1/16 of an inch (1.5 mm) and weld. This will help avoid excess static stress.

5. PACKING ADJUSTMENT

Due to the varied service applications of the valve, packing adjustment may occasionally be necessary. We recommend initial adjustment after installation and prior to start-up.

1. Remove the handle by turning the set screw counter-clockwise using the appropriate hex-socket tool.
2. Tighten the packing nut 1/8 to 1/4 of a turn.
3. Replace the handle and retighten the set screw.

6. INSTALLATION OF PANEL-MOUNTED VALVES

Valve Size	Max. Panel Thickness	Panel Hole Diameter
1/4"	6.5 mm	19.3 mm
1/2"	6.5 mm	20.8 mm

1. Remove the handle by turning the set screw counter-clockwise using the appropriate hex-socket tool.
2. Insert the valve through the panel hole and assemble the panel nut.

Note: If the valve is mounted on a thin panel, it may be necessary to fit a spacer (washer) to the valve to allow proper engagement of the panel nut.

1. If required, adjust the stem packing as explained above.
2. Replace the handle and retighten the set screw.

7. MAXIMUM ALLOWABLE WORKING PRESSURES AND TEMPERATURES

Valve Body Material	Seat Material		
	Modified PTFE	PCTFE	PEEK*
Brass	3,000 psig @ 210°C	-	-
Stainless Steel	3,000 psig @ 210°C	6,000 psig @ 148°C	6,000 psig @ 260°C
Super Duplex	6,000 psig @ 210°C	6,000 psig @ 148°C	6,000 psig @ 260°C
Alloy C-276	3,000 psig @ 210°C	3,000 psig @ 148°C	3,000 psig @ 260°C
Alloy 400	3,000 psig @ 210°C	3,000 psig @ 148°C	3,000 psig @ 260°C

For other body and seat combinations, please contact our customer service.

* Lubricant-Free cleaned valves with PEEK seats, MAWP is 3000 (260 bar) psi.

For allowable pressure at various temperatures, see the graph in the main catalogue.

WARNING!

The system designer and user have the sole responsibility for selecting products suitable for their special application requirements, ensuring their safe and trouble-free installation, operation, and maintenance. Application details, material compatibility and product ratings should all be considered for each selected product. Improper selection, installation or use of products can cause property damage or personal injury.

HEAVY DUTY BALL VALVE

H-1700 SERIES



1. USE

For maximum valve life, use the valve only within the stated pressure and temperature range, and in accordance with the corrosion resistance of the material.

2. GENERAL

The H-1700 Series is a high-pressure and high-temperature instrumentation ball valve for general service. The H-1700 series is a valve for heavy duty service due to its low operation torque, large and ergonomic handle for better grip and high cycle and thermal cyclic durability.

3. GENERAL NOTE

When a ball valve is removed or installed in a tube system, a back-up wrench (spanner) must be used on the end connector, NOT on the valve body.

Tube Fitting Connectors (LET-LOK® Twin-Ferrule Compression Fittings)

1. Insert the tubing, nesting it in the counterbore.
2. Ensure that the nut is finger tight, and mark the nut for reference.
3. Now tighten the nut 1 1/4 turns. **Note:** Note: For sizes 1/16" to 3/16" (2mm to 4 mm), tighten 3/4 of a turn only from the finger tight position.

4. OPERATION

To open or close the valve, turn the handle 1/4 of a turn (90°)

5. CLEANING THE VALVE

A ball valve can trap fluids in the ball cavity when it is in the closed position. If the valve was used in a hazardous medium, decontaminate it before disassembly. All personnel involved in the removal and disassembly of the valve should wear appropriate protective clothing, such as face shields, aprons, gloves, etc. gloves, etc.

6. TAPER THREADED CONNECTORS (NPT, BSPT, MALE OR FEMALE)

1. On the male thread of the connector, apply PTFE tape or a high-quality sealing compound. When PTFE tape is used, no more than two full turns of the tape should be applied. The tape must not overhang the end of the connector.
2. Screw the valve and connector together until they are hand tight.
3. With the proper size wrench (spanner), holding both sides of the connector (not the valve body), continue to tighten until a leak-tight joint is achieved.

7. DISASSEMBLY PROCEDURES

With the valve clamped firmly in a vise:

- Remove the nut, spring washer, handle, Belleville washer, thrust washer and top packing. Place in a secure, clean area. Remove the end connection/internal nut and body seal.
- Rotate the ball to the closed position and remove the ball and seat seals. Inspect the ball for any surface damage. If there are no nicks, scratches or other surface damage, place the ball in a clean, secure area.
- Remove the stem, and lower the packing from the body cavity.
- Scrap all plastic parts and replace them with authorized UCT parts.
- Clean and inspect all metal parts, and replace as necessary with authorized UCT parts.

8. REASSEMBLY

Reverse the steps above, taking care to lubricate all of the parts with an appropriate lubricant.

9. NOTES:

- The end connection/internal nut must be firmly closed.
- The stem nut must be closed with sufficient torque to deflect the belleville washer.

WARNING!

The system designer and user have the sole responsibility for selecting products suitable for their special application requirements, ensuring their safe and trouble-free installation, operation, and maintenance. Application details, material compatibility and product ratings should all be considered for each selected product. Improper selection, installation or use of products can cause property damage or personal injury.

3-PIECE BALL VALVES

H-500 SERIES



1. USE

For maximum valve life, use the valve only within the stated pressure and temperature range, and in accordance with the corrosion resistance of the material.

2. MANUAL OPERATION

- A. To open or close the valve, turn the handle 1/4 of a turn (90 degrees). When the valve is in the Open Position the handle is parallel (in-line) with the valve or pipeline.
- B. When the valve is in the Closed Position, the handle is perpendicular (crossed) to the valve or pipeline.

3. AUTOMATED OPERATION

Check all valves with an actuator for valve- stem alignment. Angular or linear misalignment will result in high operational torque and unnecessary wear on the stem seal.

4. DISASSEMBLING & CLEANING OF THE VALVE:

A ball valve can trap fluids in the ball cavity when it is in the closed position. If the valve was used in a hazardous medium, decontaminate it before disassembly.

- A. Relieve the line pressure.
- B. Place the valve in the half- open position and flush the line to remove any hazardous material from the valve.
- C. All personnel involved in the removal and disassembly of the valve should wear proper protective clothing, such as face shields, aprons, gloves, etc.

5. REPLACING SEATS, JOINT GASKETS, STEM SEAL AND STEM PACKING

Model H-500 is designed with Belleville washers for automatic seal wear compensation. If there is any sign of leakage from the stem, replace the stem packing and the stem seal. If there is any sign of internal leakage, replace the ball seats. When replacing the seats and joint gaskets, refer to the assembly diagram.

- A. Follow the above Disassembling & Cleaning Instructions (number 4, above). Make sure the pipe line is depressurized.
- B. With the valve in the open position (lever parallel to the axis of the pipe), loosen all the nuts on the body bolting. Remove all the bolts except one. Swing the body outside the pipe.
- C. Turn the handle to the half-open position to assist in the removal of the seats.
- D. Replace with a new set of seats and joint gaskets.
- E. Swing the body back into position. Replace the removed bolt and tighten the bolts according to the Bolt Tightening.

When replacing the stem seal and stem packing, refer to the assembly diagram.

- A. Follow the direction for replacing the seats and joint gaskets from 5.1.A to 5.1.C.
- B. To assist in loosening the stem nut, place a rod of a diameter smaller than the ball orifice into the ball orifice. Loosen and remove the top stem nut with a wrench. Remove the stem washer, handle and lock saddle. Place all removed parts in a clean and secure place.
- C. Loosen and remove the second stem nut with a wrench. Remove the set of Belleville washers. Place all removed parts in a clean and secure place.
- D. Remove the rod. Turn the valve to the closed position (handle perpendicular to the pipeline). Remove the seats and gaskets. The ball should slide out with a gentle push. Place all removed parts in a clean and secure place.
- E. Push the stem downward. It should come out through the center body. Remove the stem, then remove the stem seal.
- F. Thoroughly clean the stem. Replace it with a new stem seal.
- G. Remove the stem packing from the center body cavity. Thoroughly clean the center body. Insert a new stem packing.
- H. Replace the stem, the Belleville washers and the gland. Replace the first stem nut. To tighten the nut, hold the stem in place and tighten the nut with a wrench. When tightening the stem nuts, make sure they are snug and the Belleville washer is compressed to the maximum extent. Replace the lock saddle, the stem handle, the stem washer and the top stem nut. Tighten the top stem nut with a wrench.
- I. Turn the valve to the closed position (handle perpendicular to the pipeline). Replace the ball. Turn the valve to the open position (handle parallel to the pipeline). Replace the seats and joint gaskets.
- J. Swing the center body back into position. Replace the removed bolts and nuts.

6. GENERAL INFORMATION FOR ON-SITE

Installation:

- A. The valve may be fitted in any position on the pipeline.
- B. To prevent damage to the seats and ball surface, make sure the pipeline is flushed, free of dirt, burrs and welding residues before installing the valve.

BALL VALVES WITH LOCKING DEVICE

H-700 SERIES



1. USE

For maximum valve life, use the valve only within the stated pressure and temperature range, and in accordance with the corrosion resistance of the material.

2. OPERATION

To open or close the valve, turn the handle 1/4 of a turn (90°).

3. CLEANING THE VALVE

A ball valve can trap fluids in the ball cavity when it is in the closed position. If the valve was used in the hazardous medium, decontaminate it before disassembly. All personnel involved in the removal and disassembly of the valve should wear appropriate protective clothing, such as face shields, aprons, gloves, etc.

4. DIASSEMBLY PROCEDURES

With the valve clamped firmly in a vise:
Remove the nut, spring washer, handle, Belleville washer, thrust washer and top packing. Place in a secure, clean area.

- Remove the end connection/internal nut and body seal.
- Rotate the ball to the closed position and remove the ball and seat seals. Inspect the ball for any surface damage. If there are no nicks, scratches or other surface damage, place the ball in a clean, secure area.
- Remove the stem, and lower the packing from the body cavity.
- Scrap all plastic parts and replace them with genuine UCT replacement parts.
- Clean and inspect all metal parts and replace as necessary with authorized UCT parts.

REASSEMBLY

Reverse the steps above, taking care to lubricate all of the parts with an appropriate lubricant.

NOTES:

- The end connection/internal nut must be firmly closed.
- The stem nut must be closed with sufficient torque to deflect the Belleville washer.

WARNING!

The system designer and user have the sole responsibility for selecting products suitable for their special application requirements, ensuring their safe and trouble-free installation, operation, and maintenance. Application details, material compatibility and product ratings should all be considered for each selected product. Improper selection, installation or use of products can cause property damage or personal injury.

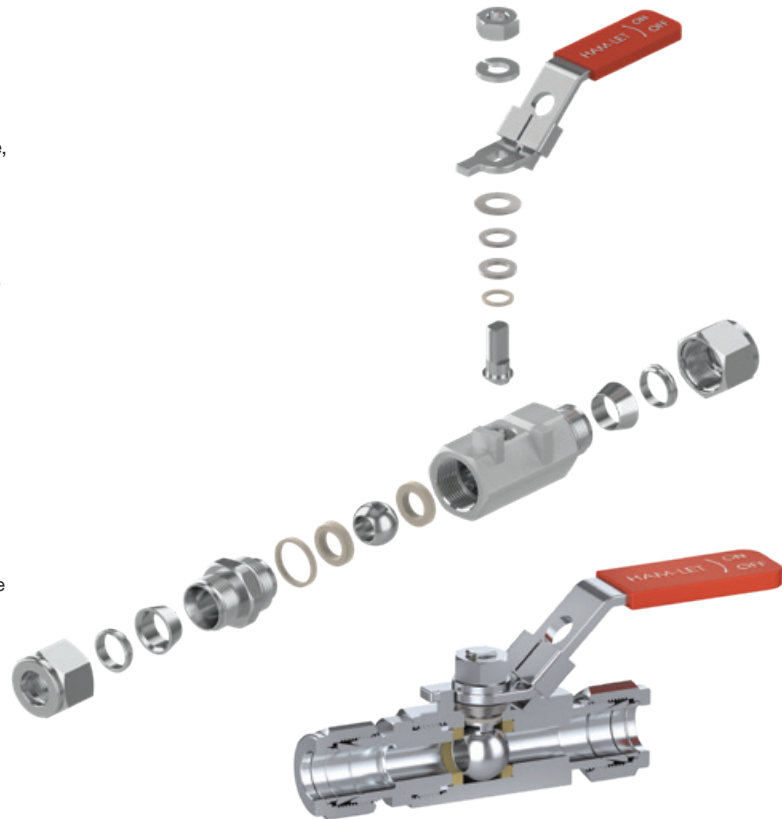

SCREWED BONNET NEEDLE VALVES

H-99 SERIES



1. USE

For maximum valve life, use the valve only within the stated pressure and temperature range, and in accordance with the corrosion resistance of the material.

2. OPERATION

To open the valve, rotate the handle until it comes in contact with the lower gland. This will allow maximum flow through the valve.

To close the valve, rotate the handle until the stem tip comes into contact with the seat.

Do not use excessive force when closing the valve. Excessive torque applied to the handle may damage both the seat and the stem tip.

3. CLEANING THE VALVE

Liquids can be trapped within the valve. If the valve was used with hazardous media, it must be decontaminated before disassembly. All personnel involved in the removal and disassembly of the valve should wear appropriate protective clothing, such as face shields, aprons, gloves, etc.

4. REPLACING SEAT AND STEM SEALS

If there are signs of leakage through the stem area, and further adjustment is not possible, replace the stem seal.

If there are signs of leakage across the seat, replace the stem.

5. DISASSEMBLY PROCEDURES

With the valve clamped firmly in a vise:

- Remove the set screw (1) with the appropriate Allen wrench, and remove the handle (2).
- Remove the packing bolt (3).
- Rotate the stem counter clockwise until the stem is free from the body.

Note: The stem will be complete with upper gland (4) the packing (5)

- Clean and inspect all metal parts for nicks, scratches, etc., particularly the stem tip and the valve seat. Discard any parts that are damaged and replace them with authorized UCT parts. Discard the stem packing and replace it with authorized UCT parts.

RE-ASSEMBLY

Reverse the steps above, taking care to lubricate all parts with an appropriate lubricant.

Note: Factory valves are tested at 1,000 psig using N2. No leakage from the seat or the stem is allowable after 1 minute with the valve immersed in water.

6. INSTALLATION DISASSEMBLY

- On taper threads, use a conventional thread sealant such as PTFE tape or an appropriate alternative that is compatible with the application.
- Apply a wrench to the body and connecting nut. Do not use the handle to tighten the connection. LET-LOK® Valves.
- Ensure the tubing is cut square and that it is de burred.
- Ensure the tubing is located firmly in the connection.
- From the finger-tight position, rotate the nut a full 1 1/4 turn.

Note: For sizes 3/16" (4mm) or less, rotate the nut 3/4 turn only. Apply a wrench to the body and connecting nut. Do not use the handle to tighten the connection.

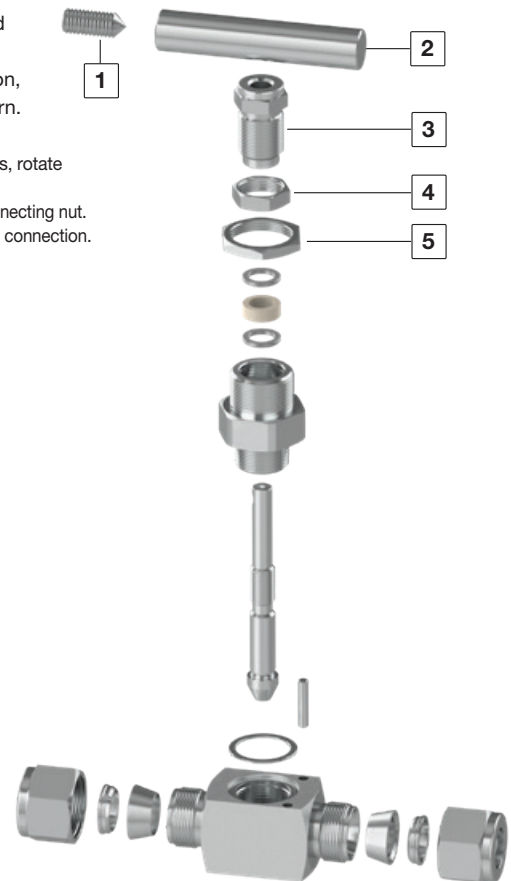

NEEDLE VALVES

H-300U SERIES



1. USE

For maximum valve life, use the valve only within the stated pressure and temperature range, and in accordance with the corrosion resistance of the material.

2. OPERATION

To open the valve, rotate the handle until it meets the lower gland. This will allow maximum flow through the valve. To close the valve, rotate the handle until the stem tip meets the seat. Do not use excessive force when closing the valve.

Excessive torque applied to the handle may damage both the seat and stem tip, particularly the soft seat option.

3. CLEANING THE VALVE

Liquids can be trapped within the valve. If the valve was used with hazardous media, it must be de-contaminated before disassembly.

All personnel involved in the removal and disassembly of the valve should wear appropriate protective clothing, such as face shields, aprons, gloves, etc.

4. REPLACING SEAT AND STEM SEALS

If there are signs of leakage through the stem area, and further adjustment is not possible, replace the stem seal. If there are signs of leakage across the seat, replace the stem.

5. DISASSEMBLY PROCEDURES

With the valve clamped firmly in a vise:

- Remove the set screw (2) with the appropriate Allen wrench, and remove the handle (1).
- Remove the packing bolt (3).
- Rotate stem counter clockwise until the stem is free from the body

Note: The stem will be complete with Belleville washers (4) gland (5) upper packing (6) and lower packing (7).

Clean and inspect all metal parts for nicks, scratches, etc., particularly the stem tip and the valve seat.

Discard any parts that are damaged and replace them with authorized UCT parts.

- Discard the stem packings and replace it with authorized UCT parts.

RE-ASSEMBLY

Reverse the steps above, taking care to lubricate all parts with an appropriate lubricant.

Note: Factory valves are tested at 1,000 psig using N₂.

No leakage from the seat or the stem is allowable after 1 minute with the valve immersed in water.

6. THREADED VALVES

INSTALLATION

On tapered threads, use a conventional thread sealant such as PTFE tape or an appropriate alternative that is compatible with the application.

- Apply a wrench to the body and connecting nut.
- Do not use the handle to tighten the connection.

LET-LOK VALVES

- Ensure the tubing is cut square and that it is deburred.
- Ensure the tubing is located firmly in the connection.
- From the finger-tight position, rotate the nut a full 1 1/4 turn.

Note: For sizes 3/16 inch (4mm) or less, rotate the nut 3/4 turn only. Apply a wrench to the body and connecting nut. Do not use the handle to tighten the connection.

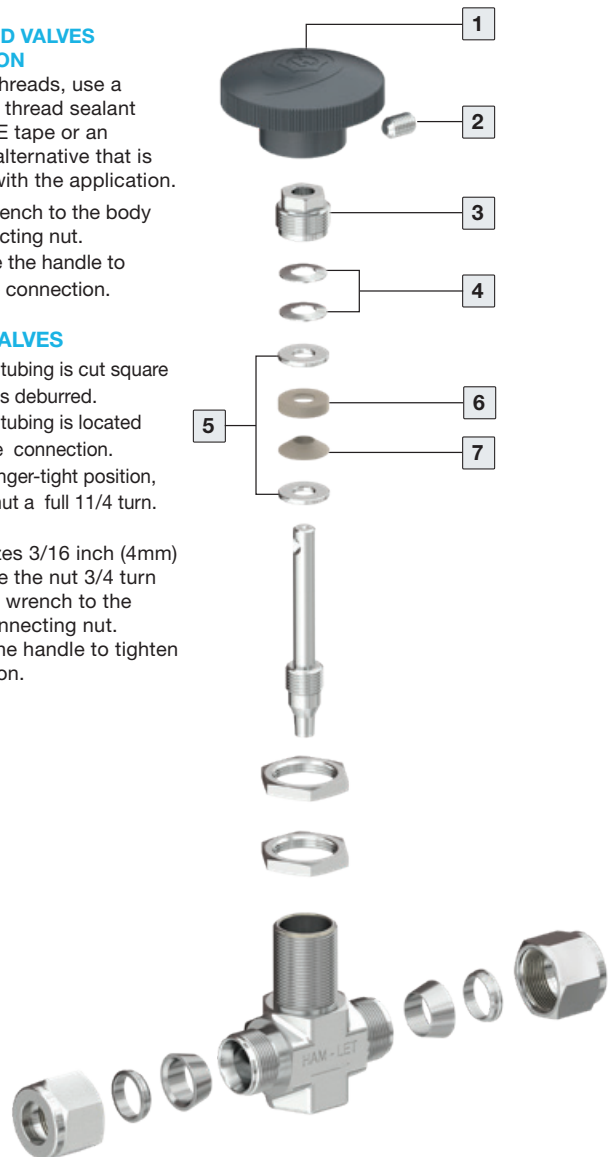

CHECK VALVES

H-400 SERIES



1. USE

For maximum valve life, use the valve only within the stated pressure and temperature range, and in accordance with the corrosion resistance of the material. Give particular attention to the compatibility of the O-ring material.

2. DISASSEMBLING AND CLEANING THE VALVE

A non-return valve can trap fluids within the body. If the valve was used in hazardous media service, remove with great care and take appropriate decontamination measures.

All personnel involved in the removal and disassembly of the valve should wear proper protective clothing, such as gloves, aprons, face shields, etc.

3. REPLACING SEATS, SEALS AND SPRINGS

H-400 valves are designed to give an optimum life span.

Should the valve reveal leaks across the seat:

A. Place the body securely in a vise, holding on to the hexagon flats. With an appropriate size wrench, unscrew the end. Remove the upper (body) and poppet O-rings. Clean and dry all parts, taking particular care that the seat is not damaged.

B. To rebuild the valve: Replace O-rings. Lubricate the threads and outer surface of the poppet with Halocarbon 27 oil, or an alternative as appropriate for the flowing medium. Reassemble the poppet and the spring into the body. Reassemble the end to the body using a torque wrench set to 33 ft. lb (45 NM).

C. Should the valve exhibit an opening at less than the stated cracking pressure, follow steps 3A and 3B, replacing the spring with a factory-supplied component.

4. TESTING

Test all valves for functionality before placing them into service. Using clean, dry nitrogen, pressurize the inlet of the valve to cracking pressure. Acceptance criterion: the valve does not pass the nitrogen at $\pm 20\%$ of cracking pressure when immersed in water for one (1) minute.

Using clean, dry nitrogen, pressurize the outlet of the valve to 2000 psig. Acceptance criterion: no leakage from the body/end connection when it is immersed in water for one (1) minute.

5. INSTALLATION

Apply wrench on the hexagon adjacent to the end being connected.

Do not grip the body with vise grips or similar tools.

WARNING!

The system designer and user have the sole responsibility for selecting products suitable for their special application requirements, ensuring their safe and trouble-free installation, operation, and maintenance.

Application details, material compatibility and product ratings should all be considered for each selected product. Improper selection, installation or use of products can cause property damage or personal injury.

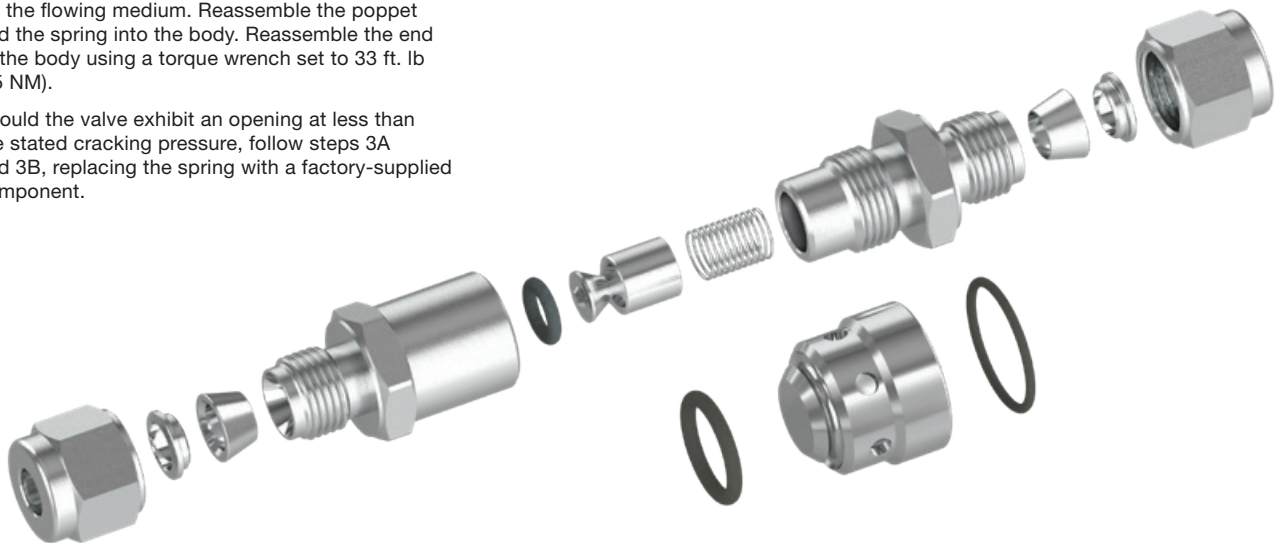

RELIEF VALVES

H-900 SERIES



1. INTRODUCTION

The H-900 Series Relief Valves are designed and tested in accordance with MSS standard SP-99-1994 (R2005) - (Instrument Valves). These type of valves are intended for use under relatively low operating pressures (ranging from 10 psig to 225 psig), in unfavorable working conditions and can be implemented in either gas or liquid applications. The valves are manufactured from ASTM-A276 body construction and are available in male and female NPT / BSPT pipe threads and LET-LOK (compression) connectors.

2. USE

For maximum valve life, use the valve only within the stated pressure and temperature range, and in accordance with the corrosion resistance of the material.

3. GENERAL

H-900 series is a relief valve intended for use in low-pressure applications. The valve is normally closed and opens when the system pressure reaches a set level. It then returns to the closed position when the system pressure falls below the set level.

4. FEATURES

- Made from SST 316.
- Service pressure up to 300psig.
- Available set pressures between 10 psig and 225 psig (0.69 to 15.5 Bar).
- Available in male and female NPT / BSPT pipe threads and Let-Lok (compression) connectors.
- Available sizes: 1/4" or 6mm.

5. CLEANING & PACKAGING

Every H-900 series Relief valve is cleaned in accordance with Standard Cleaning and Packaging (procedure 8184).

Oxygen Clean & Lubricant-Free Cleaning and packaging, in accordance with Special Cleaning and Packaging (procedure 8185), is available as an option.

TESTING

The designs of the UCT H-900 Series Relief Valves have been tested for proof, burst and leakage. Every relief valve is factory-tested for proper set and resealing performance.

6. SAFETY INSTRUCTIONS

GENERAL

- All installation and/or maintenance operations must be obtained when the system pressure is fully relieved.
- All installation and/or maintenance operations must follow User Manual Instructions.
- Use only appropriate tools, which are designed and built for the specific operation.
- Plan your action carefully in advance, especially when dealing with extreme temperature, pressure and corrosive materials.
- Use proper protection and safety devices during maintenance.

VOLUME CONSIDERATIONS

While evaluating the volume to be relieved, all system volumes should be considered, i.e.: system lines, pumps, bulk tanks, etc.

7. OXYGEN APPLICATIONS

For oxygen applications, work shall be carried out according to the procedures for working with oxygen. In a case where spare kits are ordered for oxygen clean valves, such kits have to be ordered as "oxygen clean" by adding the "- OC" designator. Example: Z-900-SK-1/4-VI-OC

WARNING!

The system designer and user have the sole responsibility for selecting products suitable for their special application requirements, ensuring their safe and trouble-free installation, operation, and maintenance. Application details, material compatibility and product ratings should all be considered for each selected product. Improper selection, installation or use of products can cause property damage or personal injury.

All safety valves which are intended to be used by 'end users' located within the European Community must be 'CE' marked.

The distributor of the valves bears the responsibility for the follow-up of the above-mentioned issue, in case he is not the "end user".

RELIEF VALVES

H-900 SERIES

(Cont'd)



Materials Of Construction

Item No.	Components	Qty.	1/4" Body Size	1/2" Body Size
1	Cap Plug	1	Polypropylene	Polypropylene
2	Adjustment Cap	1	SST 316	SST 316
3	Cap Lable	1	Polyester	Polyester
4	Locking Nut	1	SST 316	SST 316
5	Upper Spring Button	1	SST 316	-
6	Spring	1	SST 302	SST 302
7	Spring Sleeve	1	-	SST 302
8	Lower Spring Button	1	SST 316	-
8A	Lower Spring Button	1	-	SST 316
9	Bonnet	1	SST 316	SST 316
10	O-Ring	1	Fluorocarbon FKM	Fluorocarbon FKM
11	O-Ring	1	Fluorocarbon FKM	-
12	Quad Ring	1	-	Fluorocarbon FKM
13	Retaining Ring	1	PH15-7 Mo	-
13A	Location Ring	1	-	SST 316
14	Stem	1	SST 316	-
14A	Stem	1	-	SST 316
15	*Bonded Poppet	1	SST 316 bonded with Fluorocarbon FKM	SST 316 bonded with Fluorocarbon FKM
16	Insert	1	SST 316	-
17	Packing	1	PTFE	-
18	Ring	1	SST 316	-
19	Body	1	SST 316	SST 316
	Lubricant		Silicone based and PTFE based	

Dimensions

Description	Connection / Size		Dimensions mm:			
	inlet	outlet	H	N	S	L
H900	1/4" LET-LOK	1/4" LET-LOK®	37	39	50	105
H900	6MM LET-LOK	6MM LET-LOK®	37	39	50	105
H985	1/4 " Male NPT	1/4" Female NPT	32	30	40	100
H995	1/4 " Male NPT	1/4" LET-LOK®	32	39	50	100

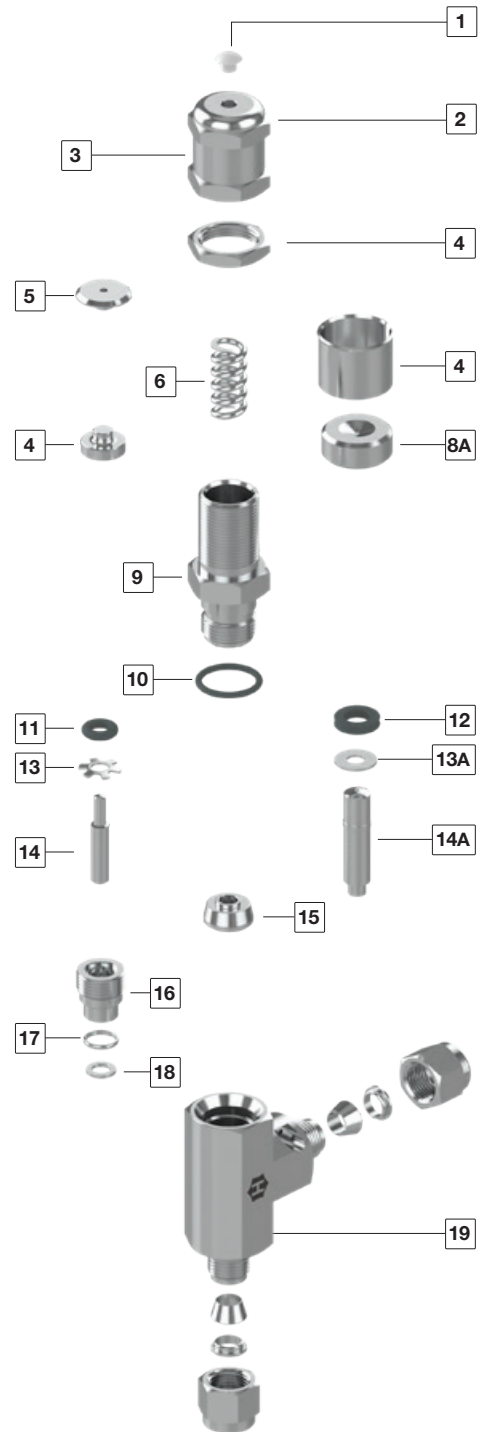
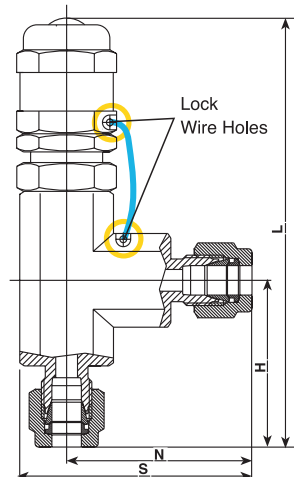

RELIEF VALVES

H-900 SERIES

(Cont'd)



7. MAINTENANCE

Tool Requirement

- 3/4" wrench.
- 5/16" Allen (Hex) key.
- O-ring installation and removal tools.
- Retaining ring installation and removal tool.

8. CRACKING PRESSURE ADJUSTMENT

1. Thread the adjustment cap (3) onto the bonnet (7) - 9 full turns.
2. Tighten the locking nut (5) against the adjustment cap (2) and test for set pressure.
3. Relieve the system pressure; unthread the adjustment cap (2) as needed (use the manual or a 3/4" wrench). Repeat the procedure as necessary to obtain the desired set pressure.
 - 3.1 A clockwise rotation of the adjustment cap (2) will increase the spring force and the cracking pressure of the valve.
 - 3.2 A counter-clockwise rotary of the adjustment cap (2) will decrease the spring force and the cracking pressure of the valve.
4. Tighten the locking nut (5) against the adjustment cap (2).
5. Lock wire the adjustment cap (2) and the valve body (17) to maintain the relief setting.

9. H-900 SERIES

Spring Installation / Replacement

Warning: Relieve the system pressure before any valve maintenance.

Content:

- 1 x Spring (4)
- 1 x Label (3)
- 1 x Lock wire
- 1 x Lead

1. Select the desired spring according to the Nominal Cracking Pressure Range as shown at the "material of construction" section above.
2. Loosen the locking nut (5) with a 3/4" wrench (clockwise) and remove the adjustment cap (2) with a 3/4" wrench (counter-clockwise) from the bonnet (7).
3. Remove the spring (4).
4. Make sure all of the components are clean of burrs.
5. Insert the selected spring (4) inside the bonnet (7).
6. Replace the existing cracking pressure range label (3) with a new one. Ensure that the pressure range, which is written on the Label (3), is in compliance with the installed spring (4) range.
7. Screw the adjustment cap (2) onto the bonnet (7) with a 3/4" wrench.
8. Perform the Cracking Pressure Adjustment procedure described above.

10. VALVE TESTING GUIDELINES

1. Connect the Relief Valve inlet to the pressure source.
2. Connect the Relief Valve outlet to any leak detecting device.
3. Increase the inlet pressure slowly.
4. Verify that an initial flow from the outlet will occur at the pre-set pressure.
5. Repeat the adjustment procedure as necessary to set the desired cracking pressure.

Note: For proper maintenance of the H-900 Series Relief

Valves, a service cycle and setting validation is recommended biannually.

The inspection, maintenance and testing can be incorporated into the annual inspection procedure to ensure proper operation and many years of trouble-free service.

The life span of the main valve seal depends upon varied factors, such as:

- Chemical resistance of the seal to the system medium.
- The volume of fluid, passed through the valve.
- The operating pressure.
- The quantity of dirt and other foreign particles present.

H-900 SERIES SEAL KIT REPLACEMENT

Content:

- 1 x O-ring (8)
- 1 x O-ring (10)
- 1 x Retaining ring (11)
- 1 x Bonded poppet (12)

11. OXYGEN APPLICATIONS

For oxygen applications, work shall be carried out according to the procedures for working with oxygen. In a case where spare kits are ordered for "oxygen clean" valves, such kits have to be ordered as oxygen clean by adding the "-OC" designator.

Example: Z-900-SK-1/4-VI-OC

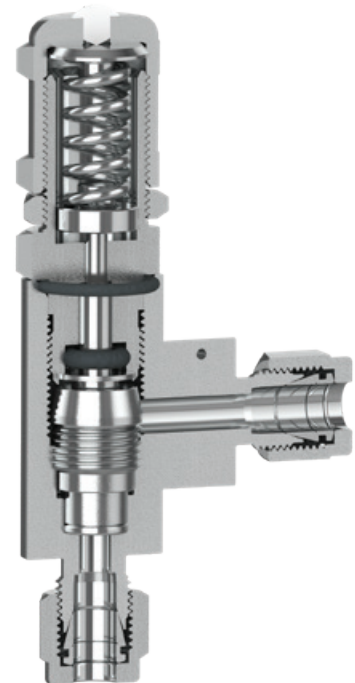

RELIEF VALVES

H-900 SERIES

(Cont'd)

12. GENERAL NOTE

When a ball valve is removed or installed in a tube system, a back-up wrench (spanner) must be used on the end connector, NOT on the valve body.

Tube Fitting Connectors (LET-LOK Twin-Ferrule Compression Fittings)

1. Insert the tubing, nesting it in the counterbore.
2. Ensure that the nut is finger tight and mark the nut for reference.
3. Now tighten the nut 1 1/4 turns.

Note: For sizes 1/16" to 3/16" inch (2 to 4 mm), tighten 3/4" of a turn only from the finger tight position.

15. TAPER THREADED CONNECTORS

(NPT, BSPT, Male or Female)

1. On the male thread of the connector, apply PFTE tape or high-quality sealing compound. When PFTE tape is used, no more than two full turns of the tape should be applied. The tape must not overhang the end of the connector.
2. Screw until the valve and connector together until they are hand tight.
3. With the proper size wrench (spanner), holding both sides of the connector (not the valve body), continue to tighten until a leak-tight joint is achieved.

16. DISASSEMBLY AND SEAL REMOVAL

Warning: Relieve the system pressure before any valve maintenance.

1. Clamp the valve body.
2. Remove the adjustment cap (2).
3. Remove the bonnet (7) from the body (17)- use a 3/4"

- wrench and rotate counter-clockwise for opening.
4. Remove stem (9) by pulling it from the bonnet (7) bore.
5. Remove the O-ring (8) from the bonnet (7).
6. Remove carefully the retaining ring (11) from the bonnet (7). Caution: The retaining ring is a spring stainless clip. Do not direct it at a person.
7. Remove the O-ring (10) from the bonnet (7).
8. Remove the bonded poppet (12) by turning the valve upside down.
9. Discard all soft (wetted) parts.
10. Inspect all parts for nicks, scratches and dents. Discard as appropriate. Replace with UCT parts only.

17. DISASSEMBLY AND SEAL REMOVAL

1. Clamp the valve body.
2. Make sure all parts are clean before installation.
3. Install a new bonded poppet (12) in the body (7) (upright position), when the seal of the bonded poppet is faced downward.
4. Install a new O-ring (10) (lubricate with system compatible lubricant) into the bonnet (7).
5. Install new retaining ring (11) (make sure the teeth are pointing away from the quad-ring).
6. Insert the stem (9) into the bonnet (7) through O-ring (9) until it bottoms.
7. Install new O-ring (8) on the bonnet (7) (Lubricate with system compatible lubricant).
8. Install the bonnet (7) into the body (17) and tighten the bonnet to 68N*m (600lb.*in).
9. Perform the adjustment procedure before installing in the system.

18. Troubleshooting Warning: Relieve system pressure before any valve maintenance.

Symptom	Possible Causes	Corrective Action
Relief valve remains open	Leakage through bonded poppet seal (13)	Replace bonded poppet (12)
Relief valve opens below set pressure	Loss of spring force/Mechanical grip.	Remove adjustment cap (2). Clean spring (4), bonnet (7) and adjustment cap (2) from particles.
Relief valve opens above set pressure	Friction on the mechanical working mechanism. Leakage through any attached auxiliary system such as emergency shutdown system, remote operators, etc.	Check auxiliary systems for leaks and readjust pressure. Disassemble, clean parts and perform cracking pressure adjustment procedure.
Unable to control the valve for shut-off	The spring range is too low.	Choose H-900HP Series valve with higher-pressure range spring.
Unable to relieve the pressure from the system after cracking	Relief valve too small. Too much gas capacity to complete cycle.	Choose a larger size of Relief valve.

For oxygen applications, work shall be carried out according to the procedures for working with oxygen. In a case where spare kits are ordered for "oxygen clean" valves, such kits have to be ordered as oxygen clean.

HIGH-PRESSURE RELIEF VALVES

H-900 HP SERIES



INTRODUCTION

The H-900HP Series Relief Valves are designed and tested in accordance with MSS standard SP-99-1994 (R2005) - (Instrument Valves).

These type of valves are intended for use under extremely high operating pressures (ranging from 50 psig to 6000 psig) and in unfavorable working conditions and can be implemented in either gas or liquid applications. The valves are manufactured from ASTM-A276 body construction and are available in male and female NPT/ BSPT pipe threads and LET-LOK (compression) connectors.

1. USE

For maximum valve life, use the valve only within the stated pressure and temperature range, and in accordance with the corrosion resistance of the material.

2. GENERAL

H-900HP series is a relief valve intended for use in high-pressure applications.

The valve is normally closed and opens when the system pressure reaches a set level.

It then returns to the closed position when the system pressure falls below the set level.

3. FEATURES

- Made from SST 316.
- Service pressure up to 6000 psig.
- Available set pressures between 50 psig and 6,000 psig (3.44 to 413.8 Bar).
- Color-coded springs for each pressure range
- Replaceable springs for a wide range of pressures
- Available in male and female NPT / BSPT pipe threads and LET-LOK (compression) connectors.
- Available sizes: 1/4" or 6mm.

4. CLEANING & PACKAGING

Every H-900HP series Relief Valve is cleaned in accordance with Standard Cleaning and Packaging (procedure 8184).

Oxygen Clean & Lubricant-Free Cleaning and packaging, in accordance with Special Cleaning and Packaging (procedure 8185), is available as an option.

5. TESTING

The designs of the UCT H-900HP Series Relief Valves have been tested for proof, burst and leakage. Every relief valve is factory-tested for proper set and resealing performance.

6. SAFETY INSTRUCTIONS

- All installation and/or maintenance operations must be performed when the system pressure is fully relieved.
- All installation and/or maintenance operations must follow User Manual Instructions.
- Use only appropriate tools, which are designed and built for the specific operation.
- Plan your action carefully in advance, especially when dealing with extreme temperatures, pressure and corrosive materials.
- Use proper protection and safety devices during maintenance.

7. VOLUME CONSIDERATIONS

While evaluating the volume to be relieved, all system volumes should be considered, i.e.: system lines, pumps, bulk tanks, etc.

WARNING!

The system designer and user have the sole responsibility for selecting products suitable for their special application requirements, ensuring their safe and trouble-free installation, operation, and maintenance.

Application details, material compatibility and product ratings should all be considered for each selected product. Improper selection, installation or use of products can cause property damage or personal injury.

All safety valves which are intended to be used by 'end users' located within the European Community must be 'CE' marked. The distributor of the valves bears the responsibility for the follow-up of the above-mentioned issue, in case he/she is not the 'end user'.

HIGH-PRESSURE RELIEF VALVES

H-900 HP SERIES

(Cont'd)

MATERIALS OF CONSTRUCTION

Item No.	Components	Qty.	1/4" Body Size	1/2" Body Size
1	Cap Plug	1	Polypropylene	Polypropylene
2	Label	1	Polyester	Polyester
3	Adjustment Cap	1	SST 316	SST 316
4	Spring	1	SST 302,17-7PH	SST 302,17-7PH
5	Lower Spring Button	1	SST 316	-
5A	Lower Spring Button	1	-	SST 316
6	Locking Nut	1	SST 316	SST 316
7	Bonnet	1	SST 316	SST 316
8	O-Ring	1	Fluorocarbon FKM	Fluorocarbon FKM
9	Quad Ring	1	Fluorocarbon FKM	Fluorocarbon FKM
10	Retaining Ring	1	PH15-7 Mo	-
10A	Location Ring	1	-	SST 316
11	Stem	1	SST 316	-
11A	Stem	1	-	SST 316 bonded with Fluorocarbon FKM
12	Clamps Screw	1	SST 316	-
13	O-Ring	1	Fluorocarbon FKM	-
14	Insert	1	SST 316	-
15	Body	1	SST 316	SST 316
	Lubricant		Silicone based and PTFE based	

DIMENSIONS

Description	Connection / Size		Dimensions mm:			
	inlet	outlet	H	N	S	L
H900-HP	1/4" LET-LOK	1/4" LET-LOK	37	39	50	105
H900-HP	6MM LET-LOK	6MM LET-LOK	37	39	50	105
H985-HP	1/4" Male NPT	1/4" Female NPT	32	30	40	100
H995-HP	1/4" Male NPT	1/4" LET-LOK	32	39	50	100

NOMINAL CRACKING - PRESSURE RANGE

psig	Bars	Spring Designator	Color
50-350	24 - 3.4	A	White
350-750	24 - 51.5	B	Blue
750-1500	103 - 51.5	C	Gold
1500-2250	103 - 155	D	Turquoise
2250-3000	206 - 155	E	Green
3000-4000	206 - 275	F	Red
4000-5000	344 - 275	G	Silver
5000-6000	344 - 413	H	Black

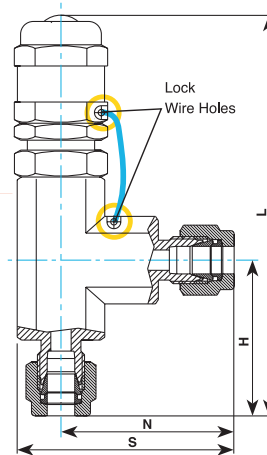
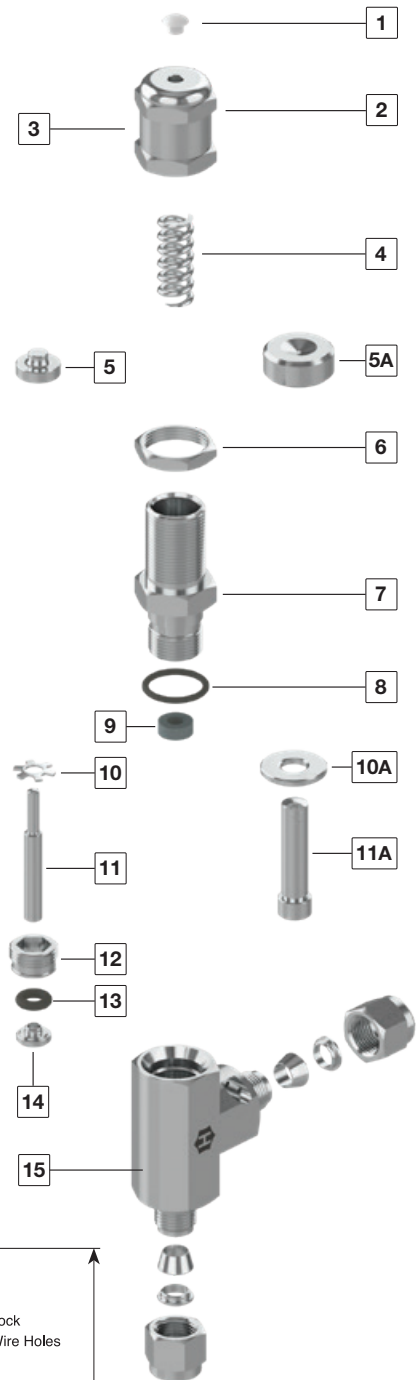
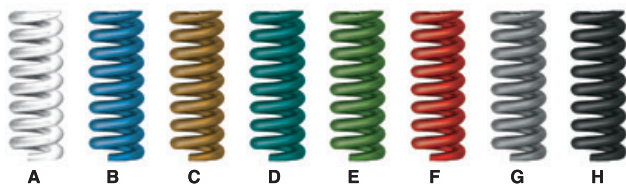

HIGH-PRESSURE RELIEF VALVES

H-900 HP SERIES

(Cont'd)

8. MAINTENANCE

TOOL REQUIREMENT

- 3/4" wrench.
- 1/4" Allen (Hex) key.
- O-Ring installation and removal tools.
- Retaining ring installation and removal tool.

CRACKING PRESSURE ADJUSTMENT

1. Thread the adjustment cap (3) onto the bonnet (7) - 9 full turns.
2. Tighten the locking nut (6) against the adjustment cap (3) and test for set pressure.
3. Relieve the system pressure; unthread the adjustment cap (3) as needed (use the manual or a 3/4" wrench). Repeat the procedure as necessary to obtain the desired set pressure.
 - 3.1 A clockwise rotation of the adjustment cap (3) will increase the spring force and the cracking pressure of the valve.
 - 3.2 A counter-clockwise rotation of the adjustment cap (3) will decrease the spring force and the cracking pressure of the valve.
4. Tighten the locking nut (6) against the adjustment cap (3).
5. Lock wire the adjustment cap (3) and the valve body (15) to maintain the relief setting.

H-900 HP SERIES

Spring Installation/Replacement

Warning: Relieve the system pressure before any valve maintenance.

Content:

- 1 x Spring (4)
- 1 x Label (3)
- 1 x Lock wire
- 1 x Lead

1. Select the desired spring according to the Nominal Cracking Pressure Range as shown at the "material of construction" section above.
2. Loosen the locking nut (6) with a 3/4" wrench (clockwise) and remove the adjustment cap (3) with a 3/4" wrench (counter-clockwise) from the bonnet (7).
3. Remove the spring (4).
4. Make sure all of the components are clean of burrs.
5. Insert the selected spring (4) inside the bonnet (7).
6. Replace the existing cracking pressure range label (2), with a new one. Ensure that the pressure range, which is written on the Label (2), is in compliance with the installed spring (4) range.
7. Screw the adjustment cap (3) onto the bonnet (7) with a 3/4" wrench.
8. Perform the Cracking Pressure Adjustment procedure described above.

9. VALVE TESTING GUIDELINES

1. Connect the Relief Valve's inlet to the pressure source.
2. Connect the Relief Valve's outlet to any leak detecting device.
3. Increase the inlet pressure slowly.
4. Verify that an initial flow from the outlet will occur at the pre-set pressure.
5. Repeat the adjustment procedure as necessary to set the desired cracking pressure.

Note: For proper maintenance of the H-900HP Series Relief Valves, a service cycle and setting validation every 6 months is recommended. The inspection, maintenance and testing can be incorporated into the annual inspection procedure to ensure proper operation and many years of trouble-free service. The life span of the main valve seal depends upon varied factors, such as:

- Chemical resistance of the seal to the system medium.
- The volume of fluid, passed through the valve.
- The operating pressure.
- The quantity of dirt and other foreign particles present.

H-900 HP SERIES SEAL KIT REPLACEMENT CONTENT:

- 1 x O-Ring (8)
- 1 x Quad-ring (9)
- 1 x Retaining ring (10)
- 1 x O-Ring (13)

10. OXYGEN APPLICATIONS

For oxygen applications, work shall be carried out according to the procedures for working with oxygen. In a case where spare kits are ordered for "oxygen clean" valves, such kits have to be ordered as "oxygen clean" by adding "-OC" designator.

Example: Z-900-HP-SK-1/4-VI-OC

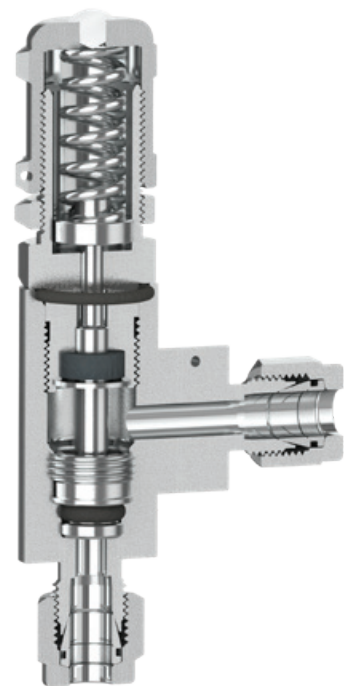

HIGH-PRESSURE RELIEF VALVES

H-900 HP SERIES

(Cont'd)

11. DISASSEMBLY AND SEAL REMOVAL

Warning: Relieve the system pressure before any valve maintenance.

1. Clamp the valve body in a vise.
2. Remove the adjustment cap (3).
3. Remove the bonnet (7) from the body (15) - use a 3/4" wrench and rotate counter-clockwise for opening.
4. Remove the poppet (11) by pulling it from the bonnet (7) bore.
5. Remove the O-ring (8) from the bonnet (7).
6. Carefully remove the retaining ring (10) from the bonnet (7).
Caution: The retaining ring is a spring stainless clip. Do not direct it at a person.
7. Remove the Quad-ring (9) from the bonnet (7).
8. Remove the clamp screw (12) from the body (15). Rotate the clamp screw counterclockwise for opening. Use a 1/4" Allen (hex) key.
9. Remove the O-ring (13) from the body (7).
9. Remove the O-ring (13) from the body (7).
10. Discard all soft (wetted) parts.
11. Inspect all parts for nicks, scratches and dents. Discard as appropriate. Replace with UCT parts only.

12. REASSEMBLY AND SEAL INSTALLATION

1. Clamp the valve body in a vise.
2. Make sure all parts are clean before installation.
3. Install a new O-ring (13) in the body (7) (lubricate with system compatible lubricant).
4. Thread clamp screw (12) in the body (15).
5. Install new quad-ring (9) (Lubricate with system compatible lubricant) into the bonnet (7).
6. Install new retaining ring (10) (make sure the teeth are pointing away from the quad-ring).
7. Insert the poppet (11) into the bonnet (7) through the Quad ring (9) until it bottoms.
8. Install new O-ring (8) on the bonnet (7) (Lubricate with system compatible lubricant).
9. Install the bonnet (7) into body (15) and tighten bonnet to 68N*m (600lb.*in).
10. Perform the adjustment procedure before.

13. Troubleshooting **Warning:** Relieve system pressure before any valve maintenance.

Symptom	Possible Causes	Corrective Action
Relief valve remains open	Leakage through O-Ring seal (13).	Replace O-Ring (13).
Relief valve opens below set pressure	Loss of spring force/ Mechanical grip.	Remove adjustment cap (3). Clean spring (4), bonnet (7) and adjustment cap (3) from particles.
Relief valve opens above set pressure	Friction on the mechanical working mechanism. Leakage through any attached auxiliary system such as emergency shutdown system, remote operators, etc.	Check auxiliary systems for leaks and readjust pressure. Disassemble, clean parts and perform cracking pressure adjustment procedure.
Unable to control the valve for cracking	The spring range is too high.	Choose a spring with lower pressure range.
Unable to control the valve for shut-off	The spring range is too low.	Choose a spring with higher-pressure range.
Unable to relieve the pressure from the system after cracking	Relief valve too small. Too much gas capacity to complete cycle.	Choose a larger size of Relief valve.

For oxygen applications, work should be carried out according to the procedures for working with oxygen. In a case where spare kits are ordered for "oxygen clean" valves, such kits have to be ordered as oxygen clean.

T-TYPE & IN-LINE FILTERS

H-600 SERIES

(Cont'd)



H-600 IN-LINE FILTER

Customer Instructions for Disassembly and Reassembly

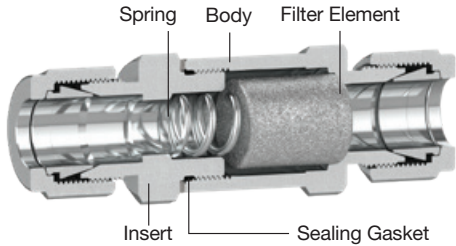

DISASSEMBLY

Use a suitable wrench to loosen the body from the insert, then remove the element, spring and sealing gasket.

REASSEMBLY

1. Prior to reassembly, clean the filter house and make sure that all other components are clean and free of contaminants.
2. Place the element in the filter body so that the open end of the element is parallel to the element seat diameter.
3. Lubricate the sealing gasket gently. We recommend using: Fluorolube grade T-80 oil. Put the sealing gasket in its place.
4. Mount the sealing gasket on the insert.
5. Place the spring inside the insert.
6. Close the nut manually. Make sure that the sealing gasket is correctly placed.
7. Use a moment wrench to affix the insert more tightly onto the body, according to the Table below.
8. Connect the filter to the pressure line and check the filter for correct operation. Use liquid leak detectors to ensure there is no leakage.

TABLE NUT TIGHTENING MOMENT LB FT (NM)

	Standard Assembly		With no lubrication on the sealing gasket (used for special applications)	
	SS	Brass	SS	Brass
H-600 -1/8" H-600-3mm	7.4 (10)	5.9 (8)	11.8 (16)	5.9 (8)
H-600 -1/4" H-600 - 6mm	19.9 (27)	11.0 (15)	33.2 (45)	16.2 (22)
H-600 -3/8" H-600 -8mm H-600 -10mm H-600 -12mm H-600 -1/2"	44.3 (60)	23.6 (32)	73.8(100)	33.2 (45)

WARNING!

The system designer and user have the sole responsibility for selecting products suitable for their special application requirements, ensuring their safe and trouble-free installation, operation, and maintenance. Application details, material compatibility and product ratings should all be considered for each selected product. Improper selection, installation or use of products can cause property damage or personal injury.

H-600 FILTER T-TYPE

Customer Instructions for Disassembly and Reassembly

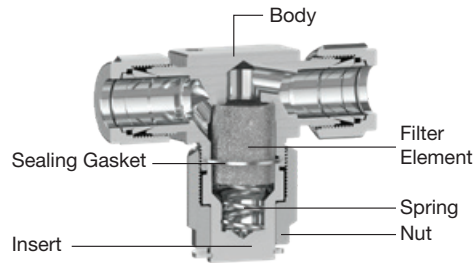

DISASSEMBLY

Use a suitable wrench to loosen the body from the insert, then remove the element, spring and sealing gasket.

REASSEMBLY

1. Prior to reassembly, clean the filter house and make sure that all other components are clean and free of contaminants.
2. Place the element in the filter body so that the open end of the element is parallel to the element seat diameter.
3. Lubricate the sealing gasket gently. We recommend using: Fluorolube grade T-80 oil. Put the sealing gasket in its place.
4. Place the spring inside the insert.
5. Close the nut manually.
6. Use a moment wrench to tighten the nut, according to the Table below.
7. Connect the filter to the pressure line and check the filter for correct operation. Use liquid leak detectors to ensure there is no leakage.

TABLE NUT TIGHTENING MOMENT LB FT (NM)

	Standard Assembly		With no lubrication on the sealing gasket (used for special applications)	
	SS	Brass	SS	Brass
H-600R -1/8" H-600R-3mm H-600R -1/4" H-600R - 6mm	44.3 (60)	39.1 (53)	47.9 (65)	39.1 (53)
H-600R -3/8" H-600R -8mm H-600R -10mm H-600R -12mm H-600R -1/2"	52.4 (71)	39.1 (53)	56.8 (77)	39.1 (53)

PRESSURE GAUGE

The information provided in this Operating and Installation, instructions guide, supplies information and guidelines relating to the selection, application, set-up options, installation and operation of pressure gauges with an elastic sensing element.

The information in this guide is to be used as guideline recommendations and does not in any way replace the users responsibility to verify and carefully select the suitable products, connections, pressure ranges and any other aspect of its application and process to ensure safe and reliable use of the products referred by this guide.

The EN873 or ASME B40.1 standards are advised to be used as reference guidelines for the selection, installation and operation of pressure gauges.

Handling and Transport:

Sensitive components!

This device contains sensitive components and must be handled with due care. To prevent any impairment of the gauge, it is essential to protect the device from mechanical shocks or impacts during transport, installation, and operation.

PRESSURE GAUGE INTERNALS AND CONSTRUCTION

ELASTIC ELEMENTS

Bourdon Tube Types:

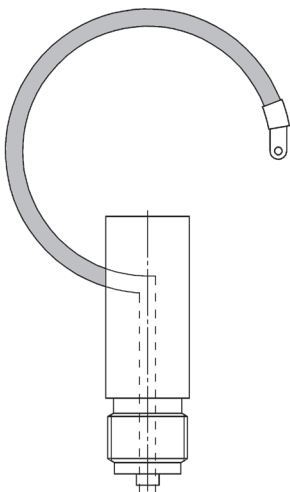

C-Type Bourdon Tube

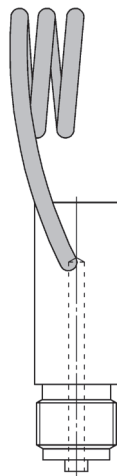

Helical Bourdon Tube

Diaphragm Type:

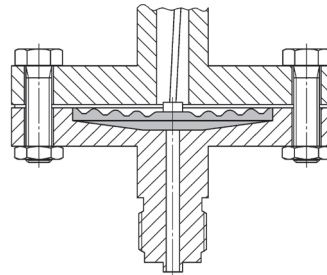

Horizontal

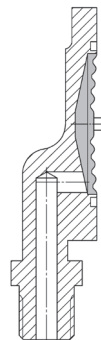

Vertical

Capsule Type:

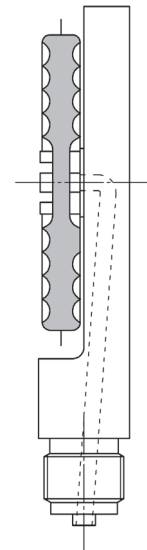

CONSTRUCTION OF PRESSURE GAUGES

PRESSURE GAUGE WITH C-TYPE BOURDON TUBE:

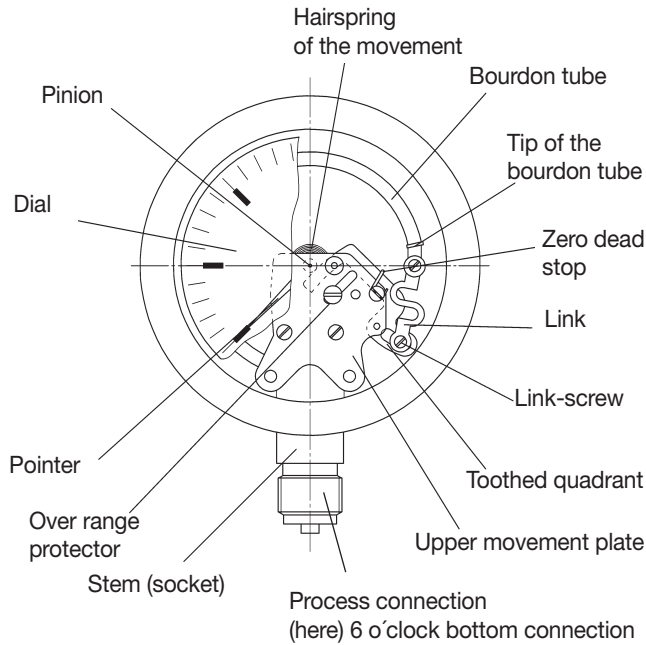

PRESSURE GAUGE WITH HORIZONTAL DIAPHRAGM:

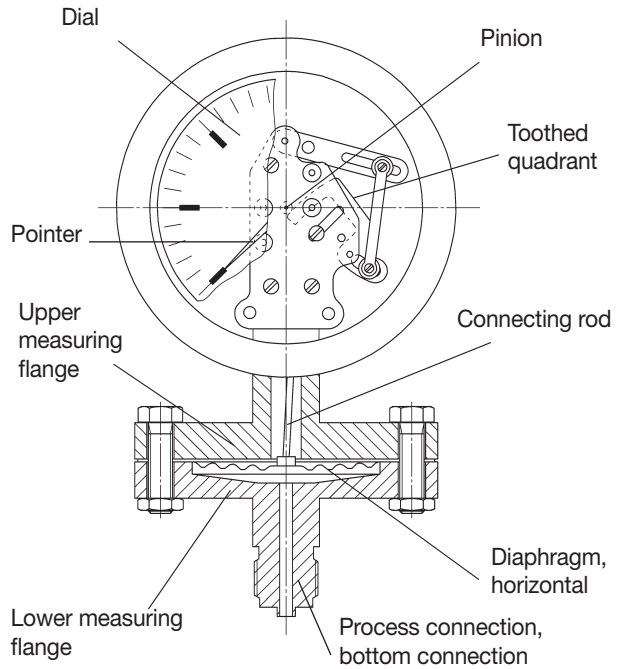

PRESSURE GAUGE WITH DIAPHRAGM CAPSULE

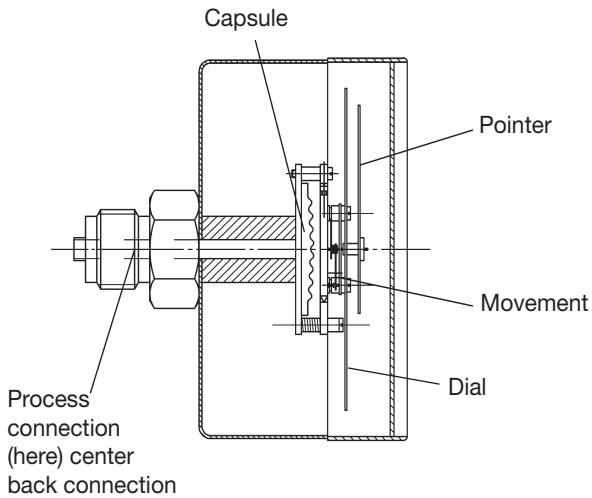

PRESSURE GAUGE WITH VERTICAL DIAPHRAGM

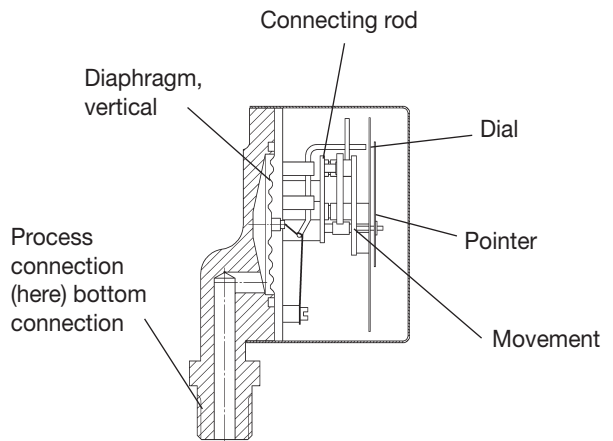

PRESSURE GAUGE IN LINE WITH SAFETY REQUIREMENTS ACCORDING TO EN 837-1, S3

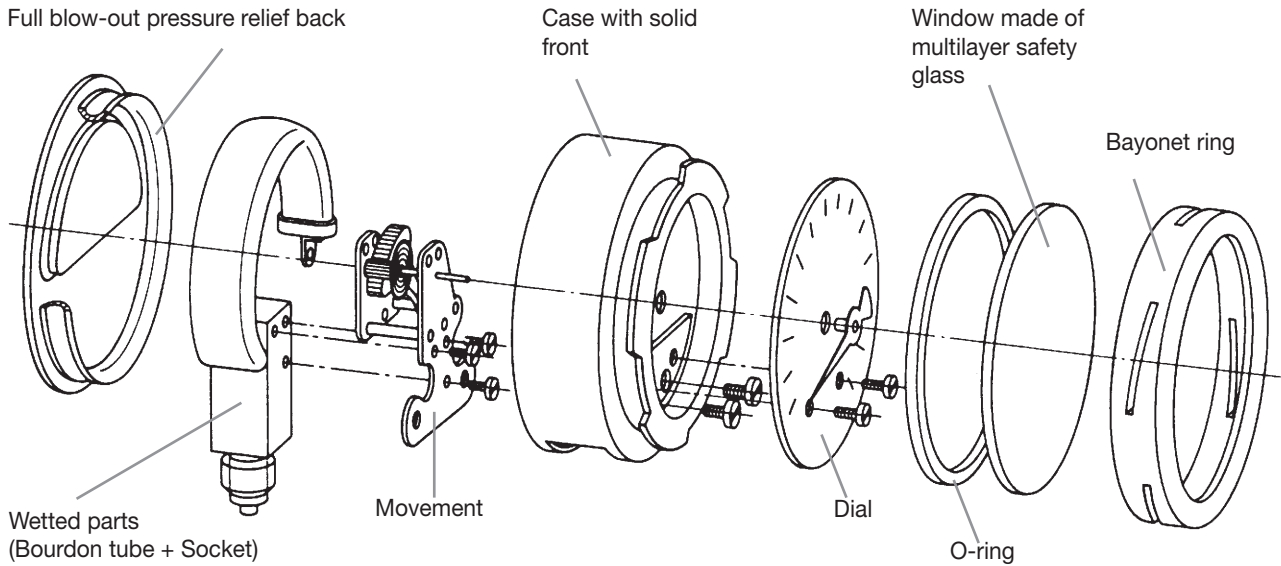

Chemical Seals

Diaphragm/Chemical seals are used to de-attach the measured media and the bourdon tube in applications where the type of media requires a total separation between it and the pressure gauge internals (the wetted parts). Chemical seals can serve higher pressures than diaphragms.

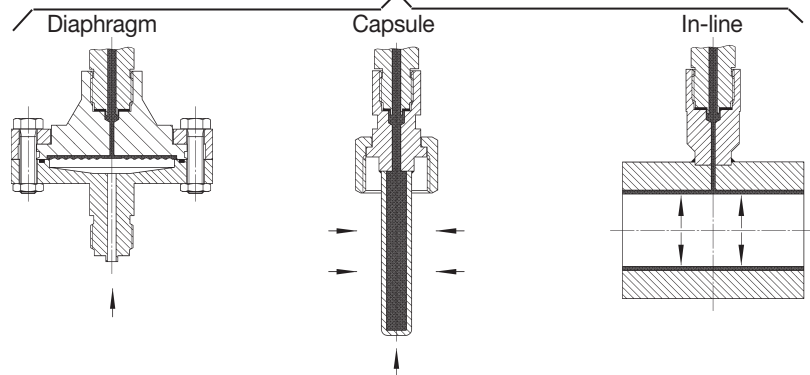
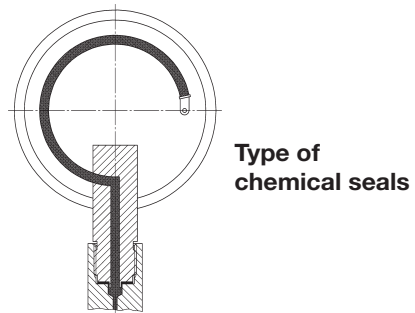

PRINCIPLES OF MEASUREMENT

The pressure gauges described in these Operating Instructions contain components which are subject to elastic deformation when exposed to pressure. This motion is transferred to a movement with a pointer. Because of their ruggedness and simple usage, these pressure gauges are widely used throughout the industry. The elastic elements themselves are generally made of stainless steel or other steel alloys.

PRESSURE GAUGES WITH BOURDON TUBE

Bourdon tubes are oval tubes bent into a circular arc. The pressure which is to be measured acts upon the interior of the tube so that the tube's oval cross section becomes approximately circular. The edge stress produced through this deforming effect causes the arc of the Bourdon tube to open. The end of the Bourdon tube which is not affixed performs a motion, this motion being a measure for the pressure.

For pressure ranges up to 40 bar, Bourdon tubes bent into a circular arc over angle of 270 degrees are commonly used, for higher pressure ranges, helical Bourdon tubes having several turns are employed.

Bourdon tubes have a relatively low restoring force. This must be taken into account when using additional accessories like indicating pointers, limit switches or potentiometric transducers since these will affect the readings obtained.

Pressure gauges with a Bourdon tube can normally only be protected in a limited way against overloading by supporting the elastic element at a specific pressure limit. Bourdon tube pressure gauges of accuracy grades between 0.6 and 2.5 are commonly used for measurements in the range between 0.6 bar to 4000 bar.

The influence of temperature changes on the indication depends mainly on the temperature coefficient (TEC= change in stiffness caused by change in temperature) that is specific for the elastic modulus of the Bourdon tube.

Depending on the material used, the accuracy error caused by temperatures differing from the reference temperature will amount to between 0.3 % and 0.4% per 10 K.

DIAPHRAGM PRESSURE GAUGES

The diaphragms are corrugated in circles. The pressure is applied to one side of the diaphragm. The degree of flexing is a measure for the pressure. Diaphragms have a relatively high restoring force. For this reason, the influence of additional accessories is less compared to gauges using Bourdon tubes.

Through the annular fixing arrangement for the diaphragm it is less sensitive to vibrations. By supporting means it is possible to protect the diaphragms against severe overloading.

By means of coatings or foils in front of the diaphragm,

the diaphragm itself may be protected against corrosive pressure media. Diaphragm gauges have an advantage when used for highly viscous and crystallizing pressure media, since optimum cleaning conditions may be provided through extended connection bores, open connection flanges or purge holes.

There are gauges with a horizontally arranged diaphragm and gauges with a vertically arranged diaphragm, i.e. where the diaphragm is placed in parallel to the dial. Generally, for pressure ranges below 0.6 bar, diaphragms that have a diameter of 160 mm are used for pressure gauges with horizontal diaphragms, whereas diaphragms that have a diameter of 100mm are used for higher pressure ranges.

Owing to the annular fixing arrangement of the diaphragm, the inaccuracy caused by temperature changes is significantly greater compared to gauges with a Bourdon tube.

Diaphragm pressure gauges are applied for pressure ranges between 10 mbar up to 25bar with standard accuracy grades of 1.6 or 2.5, in exceptional cases also 4.0.

CAPSULE PRESSURE GAUGES

A diaphragm capsule consists of two circular corrugated diaphragms or a diaphragm and a base plate joined in a pressure-tight matter at the rim.

The pressure is introduced at the center of one or of a diaphragms and acts upon the inside of the capsule. The resulting movement is a measure for the pressure. Capsule pressure gauges are not suited for liquid pressure media. They are available for pressure ranges from 2.5 mbar to 600 mbar, in accuracy grades from 0.6 to 1.6. The deviation in the readings in response to temperature changes amounts to between 0.3% and 0.4 % per 10 K, depending on the material used.

CONDITIONS OF USAGE

When selecting pressure gauges, the selection criteria and installation recommendations in accordance with EN 837-2 (ASME B40.1 standard), as well as the instructions provided herein, must be observed. The use of pressure gauges which do not meet the requirements encountered in practice can cause great consequential damage.

PRINCIPLES OF MEASUREMENT

ACCURACY LIMITS

The accuracy limits for pressure gauges have been defined in EN 837-1 for Bourdon gauges, and in EN 837-3 for capsule and diaphragm gauges (ASME B40.1 standard). Pressure gauges belonging to grade 0.1 to 0.6 and higher are preferably used in laboratories and workshops. Pressure gauges of grades 1.0 and 1.6 are mainly used for measurements on machines and production facilities. Pressure gauges belonging to grade 2.5 and 4.0 are used in monitoring measurements, where accuracy requirements are not that high.

PRESSURE RANGES

The operating pressure should be in the mid. third of the pressure range specified for the gauge. The maximum pressure load should not exceed 75 % of full-scale value at static loads, or 65 % of full-scale value for pulsating loads. Pressure Media Properties March of Pressure. The actual elastic element must not be suddenly exposed to rapid pressure changes or pressure spikes. In the case of pressure spikes, the pressure limits specified for the gauge must not be exceeded. If required overload protection means must be provided upstream. Pressure changes in excess of 10% of the full-scale value per second will impair the readings. Moreover, this will severely impair the service life of the gauges. In such cases attenuators must be provided. Through throttling components (restrictor screw or adjustable snubber) the cross section at the inlet can be much reduced in order to delay the transmission of the pressure change to the gauge. Fitting of a throttling line (a line with a reduced cross section) ahead of the gauge is also possible. In both cases the increased risk of accumulating contamination is a disadvantage. Attenuating components at the movement will only delay the movement of the pointer. Filling the case with fluids will attenuate the movement of the elastic element and will help to reduce wear on moving parts.

MEDIA TEMPERATURE

If the temperature of the pressure medium at the point where it is measured deviates from the operating temperature specified for the pressure gauge (refer to EN 837, ASME B40.1), then a sufficiently long measuring line, a siphon or a chemical seal with a capillary line, must be mounted to the pressure gauge.

The influence on the reading owing to temperatures deviating from +20 °C must be observed.

HIGHLY VISCOUS, CRYSTALLIZING AND SOLIDS CONTAINING MEDIA

When measurements are required on highly viscous, crystallizing or solids containing pressure media, the use of a diaphragm or Bourdon tube pressure gauge with attached chemical seal is recommended.

CORROSIVE PRESSURE MEDIA

If corrosive pressure media can be kept away by separating means from the elastic element, then

standard gauges may be used. Otherwise, the selection of a suitable material is mandatory, whereby the user must provide the manufacturer with all of the information on the materials which under the given conditions are compatible with the pressure medium (refer to EN 837-2 4.3). Because of the restricted choice of materials for the elastic elements, diaphragm pressure gauges with a protective lining will possibly have to be used, or chemical seals made of pressure media resistant materials need to be mounted to a Bourdon tube pressure gauge.

SAFETY

There is an increased risk combined with gases and fluids under high pressure. For example, in case of developing leaks or bursting of pressurized components, persons in front of the viewing window of the instrument must not be injured by the pressure medium escaping to the front. Safety pressure gauges with a blow-out device on the rear, fitted for example with a pressure relief.

SELECTION CRITERIA

on the back, will here offer the required degree of protection. When using hazardous pressure media, for example:

- oxygen
 - acetylene
 - combustible substances
 - toxic substances
- as well as refrigerating units, compressors etc.

The applicable regulations must be observed.

Fluid filled pressure gauges should be equipped with blow-out devices.

AMBIENT CONDITIONS

VIBRATIONS

If an exposure of the pressure gauge to vibrations cannot be avoided by way of a suitable installation, gauges equipped with damping devices for the movement, or gauges with a fluid filling, must be used.

AMBIENT TEMPERATURE

The accuracy limit given on the dial applies at a reference temperature of +20 °C.

Deviating temperature will have an influence on the reading. The magnitude of the influence will depend on the principle of measurement used.

At outdoor services, the prevailing ambient conditions must be taken into account through the selection of a suitable gauge or by introducing suitable protection means in order to prevent the formation of ice on the pressure gauge at temperatures below 0 °C, for example.

PRINCIPLES OF MEASUREMENT

For liquid filled instruments please take into consideration that the viscosity of the fluid will increase as the temperature drops, causing a delayed reading. The ambient temperature also needs to be taken into account regarding the maximum allowed operating temperature specified for the pressure gauge.

CORROSIVE ATMOSPHERE

For services at corrosive atmospheres, suitable casings and components made of corrosion Also, special surface finishing may help to protect the outside of the pressure gauges.

SETUP A GAUGE CONSIDERATIONS

CHEMICAL SEALS

In the case of aggressive, hot, highly viscous or crystallizing pressure media, chemical seals may be used as separating means ahead of Bourdon gauges in order to prevent the ingress of such pressure media into the elastic element. A neutral fluid serves the purpose of transmitting the pressure to the elastic element. The fluid must be selected depending on the measuring range, temperature, viscosity and other influences. Special emphasis must be placed on the compatibility of the fluid with the pressure medium. Chemical seals are available in a variety of different types, whereby the diaphragm seal is the most popular. In-line seals and flange type diaphragm seals must be mounted together at works suitable for the fitting position at the measuring point. The connection between the pressure gauge and the chemical seal must not be separated. Potential sources of inaccuracy by installing a chemical seal ahead of the pressure gauge need to be considered.

OVERPRESSURE PROTECTION FACILITIES

If, due to operational reasons, the pressure range of the gauge had to be chosen below the maximum operating pressure, overpressure protection devices ahead of the pressure gauge may be used to protect it against damages. In the event of pressure spikes, the over range protector will shut-down immediately, but only gradually at a slowly rising pressure.

The closing pressure which needs to be set up therefore depends on the specific pressure change with time. However, highly viscous and much contaminating pressure media may impair proper operation of the over range protector or render these ineffective. Capsule and diaphragm pressure gauges may be designed so that they themselves will be capable of resisting overpressures (up to a factor of 3, 5 or 10) without additional devices.

HOLDING DEVICES FOR THE PRESSURE GAUGE

If the line to which the gauge is connected is not strong enough to support it without introducing vibrations, then a suitable holding device for the pressure gauge should be provided.

Siphons use sufficiently long lines ahead of the pressure gauge or siphons to protect the shut-off fittings and the

gauge against being heated up by hot pressure media (steam, for example).

SHUT-OFF FITTINGS FOR PRESSURE GAUGES

It is recommended to fit shut-off devices between the measuring point and the pressure gauge. This will allow an exchange of the pressure gauge and checks on the zero setting while the system remains operative. Depending on the application, either cocks or valves are used.

Cocks have three positions:

Vent: The supply line is shut-off and the gauge is connected to the atmosphere. The zero setting may be checked.

Operation: The supply line is open and the gauge is pressurized.

Blow-out: The supply line is open and the pressure medium is allowed to escape into the atmosphere. The gauge does not work.

In the case of valves, a venting screw is usually provided between the valve seat and the pressure gauge. Venting into the atmosphere must be arranged in a way that people close by are not endangered by the escaping pressure medium.

Potential hazards to the environment must be avoided. In certain applications (steam boilers, for example), the shut-off fitting must have a test port so that the pressure gauge can be checked without having to remove it from the system. For systems with high media pressure, a high-pressure block and bleed valves or manifold should be installed between the media line and the gauge.

Different types of manifolds provide a safe means of blocking the media flow to the gauge, releasing the pressure in the gauge and to ventilating wetted gauge parts to the atmosphere or to a drain line.

SETUP ARRANGEMENTS

GENERAL:

Well proven measuring arrangements and proposals for components are advised in several standards and technical guidelines. The overview of some arrangements is shown in the following table:

State of the pressure medium	Fluid			Gaseous		
State of the Filling in the Measuring Line	Fluid	Partly Degassing	Fully Degassing	Gaseous	Partly Condensed (humid)	Fully Condensed
Examples	Condensate	Boiling Fluids	"Liquid Gases"	Dry Air	Moist Air Fuel Gas	Water Vapor
A Pressure gauge above the measurement port	1	2	3	4	5	6
B Pressure gauge below the measurement port	7	8		9	10	11
Arrangements 3, 4, 5, 7, 8 and 11 are to be preferred						

PRESSURE MEASURING PORTS

The pressure measuring port should be located at a point where the flow is not impaired in any way and where constant conditions can be ensured for the measurements.

It is recommended to provide a sufficiently large bore at the point of the pressure measurement and to provide some means for shutting the pressure measuring port off.

MEASURING LINE

The connection between the pressure measuring port and the pressure gauges is the measuring line.

The inside diameter of this measuring line should be sufficiently wide in order to avoid the risk of blockages.

The measuring line should have a steady slope (recommended is a slope of 1:15).

With gases as the pressure medium, a drain should be provided at the lowest point and with high-viscosity fluids a vent should be provided at the highest point.

In the case of gases containing solids or fluids, separators which may be demounted from the running system for emptying, should be provided. The measuring line should be designed and fitted

in a way that it will be capable of sustaining the occurring loads caused by expansion, vibration or thermal effects.

SHUT-OFF FITTINGS

Shut-off fittings at the pressure gauge serve the purpose of checking the zero setting or exchanging the pressure gauge while the system remains operational.

PRINCIPLES OF MEASUREMENT

GAUGE

The pressure gauge should be mounted to prevent vibrations and shocks and so that the dial can be read easily. When reading the dial, parallax errors should be avoided. It must be ensured that blow-out devices of the pressure gauge are not blocked. The pressure gauge must be arranged in such a manner that the temperature of the gauge does not drop below or exceed the permissible operating temperature range. In doing so, the influences of convection and thermal radiation should be taken into account.

Whenever the elastic element of a pressure gauge is filled with water or a water mixture, the instrument must be protected against frost. Usually, the pressure gauge will be fitted with the dial arranged vertically. In all other cases the position indicating symbol according to EN 837 applies.

A difference in height between the port at which the pressure is measured and the pressure gauge will cause a shift at the beginning of the reading if the pressure medium in the measuring line is of a different density compared to the ambient air. This shift Δp at the beginning of the reading results from the difference in density ($\rho_M - \rho_L$) and the difference in height Δh :

$$10^{-5} \cdot (\rho_M - \rho_L) g \Delta h$$

Δp = Shift at the beginning of the reading (bar)
 ρ_M = Density of the pressure medium kg/m³
 ρ_L = Density of the air (1.205 at 20 °C) kg/m³
 Δh = Difference in height m
 g = Acceleration due to gravity m/s²
(mean acceleration due to gravity =9.81 m/s²)

The reading is reduced by Δp if the pressure gauge is located above the pressure measurement port and increased by Δp if below the pressure measurement port.



INSTALLATION

The installation of pressure gauges should be left to skilled staff. For applying arrangement see set up arrangement above. During installation or removal, never apply any force on the case of the pressure gauges; instead apply the wrench to the wrench flats provided. It must be ensured that the matching process connection has been selected (nominal width, suitable sealing face, if required), in order to position the pressure gauge so that it can be read perfectly.

A UCT tube adapter process connection is the preferred solution, allowing free positioning when connecting to a UCT LET-LOK® fitting or valve connection.

In the case of flange joints, the pressure gauge is placed on the mating flange, and the flanges are joined using suitable bolts. Please ensure that the bolts are tightened firmly.

The joints must be leak tight. For this reason, it is mandatory that suitable gaskets made of a material resistant to the pressure medium will be used in the connections. For sealing connections with a parallel thread, for example, flat gaskets in accordance with EN 837-1 or profile seals must be fitted, or on the other hand, the corresponding sealing lens has to be provided in the case of a high-pressure connection. Tapered threads (for example NPT threads) are sealed off with additional sealants like PTFE tape, for example:

For pressure gauges with a pressure relief vent of \varnothing 13 mm at the top of the case, it is recommended for pressure ranges < 6 bar to cut off the nipple at the filling plug so that the gauge can be vented in order to compensate for the internal pressure.

If the pressure gauge is located below the pressure measurement port, the measuring line should be well purged well before starting operation so as to remove any foreign objects which might be present in the line. During pressure tests on pipes or vessels, the pressure gauge must not be exposed to excessively high pressures, as indicated by the pressure limit indicating mark ▼ on the dial, resp. The limits for a static pressure specified for the pressure gauge should not be exceeded.

When using diaphragm gauges, the clamping bolts for the upper and lower flange should not be loosened. In the case of instruments with attached chemical seals, the connection between the gauge and the chemical seal and possibly also the connection between the chemical seal and the capillary line must not be disconnected.

Before disconnecting and removing the pressure gauge unit from the measuring point, it should be

depressurized first. If required, the pressure in the measuring line must be relieved. Residues of the pressure medium in pressure gauges which have been removed may present a hazard to personnel, facilities and the environment. For this reason, suitable safety precautions should be used.

Shut-off devices should only be opened slowly in order to avoid sudden pressure spikes during start-up.

The installation of pressure gauges should be left to skilled staff. For applying arrangement see set up arrangement above. During installation or removal, never apply any force to the case of the pressure gauges; instead apply the wrench to the wrench flats provided. Please ensure that the matching process connection has been selected (nominal width, suitable sealing face, if required), in order to position the pressure gauge so that it may be read perfectly.

A UCT tube adapter process connection is the preferred solution, allowing free positioning when connecting to a UCT LET-LOK® fitting or valve connection.

In the case of flange joints, the pressure gauge is placed on the mating flange, and the flanges are joined using

suitable bolts. Please ensure that the bolts are tightened firmly.

The joints must be leak tight. For this reason, it is mandatory that suitable gaskets made of a material resistant to the pressure medium will be used in the connections. For sealing connections with a parallel thread, for example, flat gaskets in accordance with EN 837-1 or profile seals must be fitted, or on the other hand, the corresponding sealing lens has to be provided in the case of a high-pressure connection.

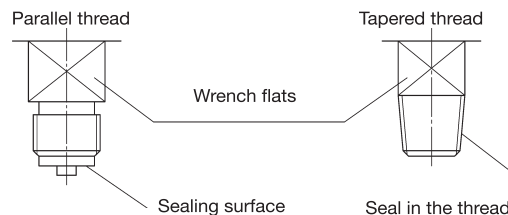
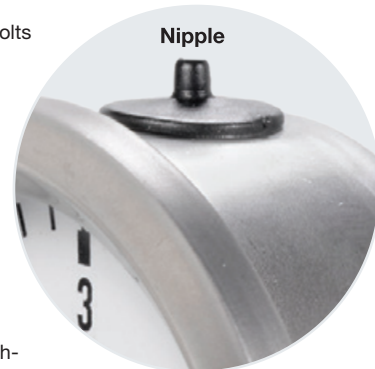

OPERATION

SPECIFIED USAGE

The usable range for static loads is indicated on the dial of many pressure gauges. Bourdon tube pressure gauges, having a nominal size of 100, 160 or 250, may be subjected to the respective full-scale pressure if the load is static.

If the pressure load is of a pulsating nature, pressure peaks amounting to only 0.9 of the full-scale pressure are permissible, and for the pressure ranges of 0/2500 bar and 0/4000 bar, pressures amounting only to 2/3 of the full-scale pressure may be applied. Bourdon tube pressure gauges can be overloaded up to 1.3 of their full-scale value (instruments 0/2500 bar and 0/4000 bar can only be overloaded up to their full-scale value!), Bourdon tube pressure gauges having a nominal size of 40, 50, 63 and 80, may only be subjected to pressures of up to 3/4 of the full span if the pressure is static, and if the pressure is of a pulsating nature, the maximum load is restricted to 2/3 of the full-scale value, and the full-scale pressure may be applied only briefly. In the case of diaphragm pressure gauges with a vertical diaphragm, pressures up to the full-scale value may be applied if static, and if the pressure is of a pulsating nature, the limit will be 0.9 of the full-scale level. Diaphragm pressure gauges with a horizontal diaphragm can sustain overpressures of up to five times their full-scale value (custom-built instruments even more), but a pressure of 40 bar must never be exceeded. Capsule pressure gauges can also be operated at their specified full-scale pressure, provided the pressure is static. If the pressure pulsates, the maximum load is only 0.9 times the full-scale value. Just like Bourdon tube pressure gauges, they are able to sustain overpressures of up to a factor of 1.3 (custom-built instruments can handle even higher overpressures).

ZERO CHECK

In order to check the zero setting of the pressure gauge during operation of the system, the required shut-off device has to be closed and the pressure in the gauge has to be relieved.

The pointer must come to rest within the zero-range indicated by . If the pointer comes to rest outside of this range, then a persisting deformation of the elastic element must be assumed so that the gauge will have to be checked in order to avoid accidents owing to incorrect measurements. In such a case the pressure gauge should be replaced and returned to the manufacturer for checking and repair, if required.

PRESSURE RANGE CHECK

If the readings supplied by the pressure gauge need to be checked while the remainder of the system is operating, the pressure gauge has to be separated from the process via the required shut-off device with the test port and a test pressure has to be applied to the gauge. The error limits according to EN 837-1 resp. EN 837-3 apply.

TEMPERATURE RESISTANCE

The permissible operating temperature for the pressure gauge must not be exceeded.

The respective temperature resistance for the permissible operating temperature ranges are generally from -40 °C to +60 °C (compare to EN 837-1 and EN 837-3), at which unfilled gauges

with a silver-brazed bourdon tube are capable up to +100 °C or argon arc welded bourdon tube are capable up to +200 °C in stainless steel cases.

Special versions can be suitable for higher temperatures.

Note: These are only information on the temperature resistance of the materials respectively the soldered joints or welded seams. The information on indication errors due to deviations from the reference temperature have to be regarded.

CLEANING TEMPERATURE

Also, when purging the measuring line, the permissible operating temperature for the pressure gauge (refer to above) must not be exceeded. If required, the gauge should be shut-off or removed.

In the case of pressure gauges with attached chemical seals, the maximum cleaning temperature must not be exceeded.

MAINTENANCE AND REPAIR

Generally, pressure gauges will not require any maintenance.

These instruments may only be repaired by the manufacturer.

Before returning an instrument for repair, all parts of the instrument in contact with the pressure medium must be cleaned with care, especially when hazardous pressure media were used before. It is a good idea to always include with the repair order a description of the pressure medium resp. a Declaration of Contamination.

ELECTRICAL ACCESSORIES

The electrical connections should be made only by skilled staff and qualified personnel. Instruments equipped with electric accessories have an adhesive label from which it is apparent how the instrument is to be electrically connected. Load limits must be observed.

Exceeding of load limits could cause greater damage. During installation, initial operation and operation of the instruments the national and international safety regulations must be observed.

OPERATION

Please ensure that the cable diameters match the nominal widths of the sealing inlets of the cable feed throughs.

Screwed joints must be tightened firmly.

Compliance with the certified protection standards can only be ensured in this way. In the case of designs with right-angled plug connectors, universal plug connectors or terminal boxes, the centrally arranged fixing screws must be tightened manually.

In connection with the DMU type pressure transducers shielded cables must be used throughout, the shield of which must be connected to housing or the ground terminal on the right-angled plug connector so as to ensure full electromagnetic compatibility (EMC).

In the case of equipment with a magnetic contact it must be noted that the CE mark in accordance with EMC guidelines will only apply if a switching frequency of 5 actuations per minute is not exceeded. In as much specified, a suitable output unit or multifunctional relay must be used (for example for instruments with inductive limit switches).

The current Operating Instructions must be observed.

STORAGE

Pressure Gauges should be left in the original packaging and should be maintained in stock well protected against damage by external influences. If the pressure gauge was taken out of its packaging and inspected briefly (for testing, for example) it should be carefully placed back in the same packaging before returning it to stock.

While the pressure gauge is in stock the general temperature limits of $-40\text{ }^{\circ}\text{C}$ and $+60\text{ }^{\circ}\text{C}$ should not be exceeded.

If in doubt or if anything remains unclear please contact the manufacturer.

INSTALLATION IN POTENTIALLY EXPLOSIVE AREAS

GENERAL INFORMATION:

Pressure Gauges are mechanical pressure measuring instruments and do not show any ignition sources when operating as intended. Versions that are made of stainless steel and contain laminated safety glass are suitable for the use in areas of category 2 and 3 according to ATEX Standard 94/ 9/EG. Only pressure measuring instruments with integrated construction type proved deflagration volume protection, our Flame arrester, are suitable for the use as category-1 instrument. This protection system prevents a flame penetration at deflagration of explosive vapor-air, respectively gas-air mixtures of explosion hazardous IIA, IIB and IIC in an up stream volume of a maximum of 0.2 l. The deflagration volume protection Flame arrester is certified IIG IIC PTM 12 ATEX 4001 X on condition that the operating pressure does not exceed 1.1 bar abs. and the operating temperature does not exceed $60\text{ }^{\circ}\text{C}$ ($140\text{ }^{\circ}\text{F}$).

To avoid warming up the measuring elements of bourdon tube pressure gauges a dynamic load with gaseous media is not allowed! For additional information and more technical support please contact your UCT representative.